

## KRAL pump stations.

EKL/EKS 11/12/13

Mechanical seal/radial shaft seal

OIK 10en-GB  
Edition 2025-04  
Original instructions

<b>1 About this document</b> .....	<b>3</b>	8.5 Removing the pump station .....	19
1.1 General information .....	3	<b>9 Connection</b> .....	<b>20</b>
1.2 Associated documents .....	3	9.1 Dangers during connection work .....	20
1.3 Target groups .....	3	9.2 Connecting the pump station to the pipe system .....	20
1.4 Symbols.....	3	9.2.1 Setup of the suction line .....	20
1.4.1 Danger levels .....	3	9.2.2 Flange connection .....	20
1.4.2 Danger signs .....	4	9.2.3 Pipe screwed connection .....	21
1.4.3 Symbols in this document .....	4	9.3 Connecting the pump station to the power supply .....	22
<b>2 Safety</b> .....	<b>4</b>	<b>10 Operation</b> .....	<b>23</b>
2.1 Proper use .....	4	10.1 Dangers during operation .....	23
2.2 Foreseeable misuse .....	4	10.2 Commissioning .....	23
2.3 Obligations of the operator-owner .....	5	10.2.1 Cleaning the pipe system .....	23
2.4 Safety instructions .....	5	10.2.2 Filling and venting the pump station .....	24
2.4.1 Fundamental safety instructions .....	5	10.2.3 Checking the direction of rotation .....	25
<b>3 Identification</b> .....	<b>6</b>	10.2.4 Commissioning the pump station .....	25
3.1 Type code.....	6	10.2.5 Venting the deaerator (optional).....	26
3.2 Rating plate .....	6	10.3 During operation .....	26
<b>4 Technical data</b> .....	<b>7</b>	10.3.1 Checking the operating pressure .....	26
4.1 Operating limits .....	7	10.3.2 Adjust overflow valve and test function .....	26
4.2 Required NPSH values .....	7	10.3.3 Setting the pressure maintaining valve .....	26
4.3 Sound pressure level.....	7	10.3.4 Switching off the pump station .....	27
4.4 Output tables .....	8	10.4 Decommissioning .....	27
4.5 Mesh width strainer/filter .....	9	10.4.1 Taking the pump station out of operation .....	27
4.6 Weights .....	9	10.5 Recommissioning .....	28
<b>5 Function description</b> .....	<b>9</b>	10.5.1 Recommissioning the pump station .....	28
5.1 Structure of standard version .....	9	<b>11 Maintenance</b> .....	<b>28</b>
5.2 Structure of special design .....	10	11.1 Dangers during maintenance.....	28
5.3 Functional principle .....	11	11.2 Required maintenance.....	28
5.4 Pressure maintaining valve .....	11	11.3 Maintaining the pump station.....	29
5.5 Pulsation damper .....	11	11.4 Maintaining the strainers.....	29
5.6 Expansion valve (optional) .....	12	<b>12 Servicing</b> .....	<b>29</b>
5.7 Protection against soiling .....	12	12.1 Dangers during servicing .....	29
5.8 Options for standard version .....	13	12.2 Wear .....	29
5.9 Options for special design .....	13	12.2.1 Signs of wear.....	29
5.10 Heating system (optional).....	14	12.3 Servicing the pump station .....	30
5.10.1 Possible types of heating .....	14	12.4 Replacing the pump .....	30
5.10.2 Electrical heating system .....	14	12.5 Cleaning the strainer.....	31
<b>6 Transportation, storage</b> .....	<b>14</b>	<b>13 Disposal</b> .....	<b>32</b>
6.1 Dangers during transportation.....	14	13.1 Dismantling and disposing of the pump station .....	32
6.2 Dangers during storage.....	14	<b>14 Troubleshooting</b> .....	<b>33</b>
6.3 Unpacking and checking the state of delivery .....	15	14.1 Possible faults.....	33
6.4 Transporting the pump station.....	15	14.2 Troubleshooting .....	33
6.5 Storing the pump station .....	15	<b>15 Spare parts</b> .....	<b>36</b>
<b>7 Preservation</b> .....	<b>16</b>	15.1 Overview .....	36
7.1 Preservation table .....	16	<b>16 Appendix</b> .....	<b>38</b>
7.2 Preserving the inner surfaces.....	16	16.1 Tightening torques for screws with metric screw threads with and without wedge lock washers.....	38
7.3 Preserving the outer surfaces .....	16	16.2 Tightening torques for screw plugs with thread measured in inches and elastomer seal .....	39
7.4 Removing the preservation .....	17	16.3 Contents of the Declaration of Conformity .....	39
<b>8 Installation, removal</b> .....	<b>17</b>		
8.1 Dangers during installation.....	17		
8.2 Dangers during removal .....	17		
8.3 Mounting the pump station .....	17		
8.4 Protecting the pump station against pressure peaks ..	18		

## 1 About this document

### 1.1 General information

These instructions form part of the product and must be kept for future reference. Furthermore please observe the associated documents.

### 1.2 Associated documents

- Declaration of conformity according to EU Directive 2006/42/EC
- Manufacturer's declaration according to EU Directive 2014/68/EU
- Corresponding operating instructions of the pump
- Technical documentation of the supplied components

Additional documents for ATEX version

- Declaration of conformity according to EU Directive 2014/34/EU
- ATEX supplementary instructions for usage in potentially explosive areas

### 1.3 Target groups

The instructions are intended for the following persons:

- Persons who work with the product
- Operator-owners who are responsible for the use of the product

Persons who work with the product must be qualified. The qualification ensures that possible dangers and material damage that are connected to the activity are detected and avoided. These persons are qualified personnel who carry out the work properly due to their training, knowledge and experience and on the basis of the relevant provisions.



Information on the required qualification of the personnel is provided separately at the beginning of the individual chapters in these instructions. The following table provides an overview.

Target group	Activity	Qualification
Transport personnel	Transporting, unloading, setting up	Qualified personnel for transport, mobile crane operators, crane operators, forklift operators
Fitter	Mounting, connection	Qualified personnel for mounting
Electrician	Electrical connection	Qualified personnel for electric installation
Trained personnel	Delegated task	Personnel trained by the operator-owner who know the task delegated to them and the possible dangers arising through improper behaviour.

Tab. 1: Target groups

### 1.4 Symbols







#### 1.4.1 Danger levels

	Signal word	Danger level	Consequences of non-observance
	DANGER	Immediate threat of danger	Serious personal injury, death
	WARNING	Possible threat of danger	Serious personal injury, invalidity
	CAUTION	Potentially dangerous situation	Slight personal injury
	ATTENTION	Potentially dangerous situation	Material damage







## 2 Safety

### 2.1 Proper use

#### 1.4.2 Danger signs

	Meaning	Source and possible consequences of non-observance
	Electrical voltage	Electrical voltage causes serious physical injury or death.
	Raised load	Falling objects can result in serious physical injury or death.
	Heavy load	Heavy loads can result in serious back problems.
	Risk of slipping	Discharging pumped liquid and oils on the foundation or tread surfaces can cause falls with serious physical injury or death.
	Flammable substances	Discharging pumped liquid and oils can be easily inflammable and can result in serious burns.
	Hot surface	Hot surfaces can cause burns.

#### 1.4.3 Symbols in this document

	Meaning
	Warning personal injury
	Safety instruction
	Request for action
	Multi-step instructions for actions
	Action result
	Cross-reference

## 2 Safety

### 2.1 Proper use

- Use the pump station solely for transporting lubricating liquids that are chemically neutral and that do not contain gas or solid components.
- Use the pump station only within the operating limits specified on the rating plate and in the chapter "Technical data". In the case of operating data that do not agree with the specifications on the rating plate, please contact the manufacturer.
- The pump station is designed specially for the operating pressure named by the customer. If the actual operating pressure deviates notably from this design pressure, damage to the pump station can also arise within the specified operating limits. This applies both to notably higher as well as to notably lower operating pressures. Under no circumstances may the minimum pressure lie below 2 bar. In case of any doubt, please contact the manufacturer.

### 2.2 Foreseeable misuse

- Any use that extends beyond the proper use or any other use is misuse.
- The product is not suitable for pumping liquids outside the operational limits.
- Any bypassing or deactivation of safety equipment during operation is prohibited.

### 2.3 Obligations of the operator-owner

The operator-owner is the person who operates the product commercially or permits a third party to use it and who bears the legal responsibility for the product, the protection of the personnel and third parties during its operation.

The product is used in industrial applications. The operator-owner is therefore subject to the statutory obligations concerning occupational health and safety.

In addition to the safety instructions in these instructions, the regulations on safety, accident prevention and environmental protection respectively valid for the range of application of the product are to be observed.

### 2.4 Safety instructions

#### 2.4.1 Fundamental safety instructions



**The following safety instructions must be observed strictly:**

- Read these operating instructions carefully and observe them.
- Read the operating instructions of the components carefully and observe them.
- Have work only carried out by qualified personnel/trained personnel.
- Wear personal protective equipment and work carefully.
- Pumped liquids can be subject to high pressure and can result in personal injury and damage to property in case of incorrect operation or damaged components.
- Pumped liquids can be hot, poisonous, combustible and caustic. Use corresponding protective equipment.
- Observe the associated data sheets and safety regulations when handling dangerous materials.
- Avoid skin contact with system parts carrying liquids at operating temperatures exceeding 60 °C.
- Collect any discharging pumped liquid safely and dispose of it in an environmentally compatible manner in accordance with the applicable local regulations. Neutralize residues.
- Keep the mounting surfaces, scaffolding, ladders, lifting platforms and tools clean in order to prevent slipping or stumbling.
- If pressurized or energized components are damaged, shut down the pump station immediately. Replace the components.

### 3 Identification

#### 3.1 Type code

### 3 Identification

#### 3.1 Type code

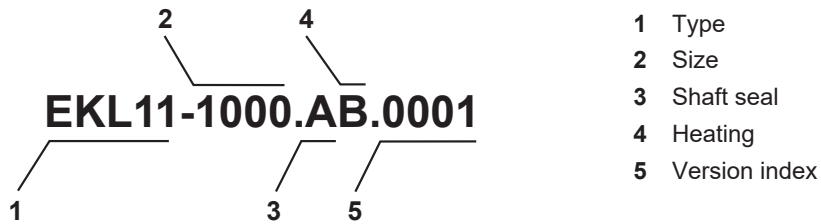

- 1 Type
- 2 Size
- 3 Shaft seal
- 4 Heating
- 5 Version index

Fig. 1: Type code

Item	Classification	Description	
1	Type	EKL	Station with pump of the K series for light oils
		EKS	Station with pump of the K series for heavy oils
		EKL/S 11	Without pressure maintaining valve
		EKL/S 12	With pressure maintaining valve
		EKL/S 13	With pressure maintaining valve and return
2	Size	Corresponds to delivery rate in [l/min] at rated speed	
3	Shaft seal	A	Standard mechanical seal
		B	Mechanical seal of hard material
		C	Standard radial shaft seal
		D	Magnetic coupling
		E	Mechanical seal with quench
		F	High-temperature radial shaft seal
		X	Special design
		4	Heating
B	Electrical heating system		
5	Version index	For internal administration	

Tab. 2: Type code

#### 3.2 Rating plate

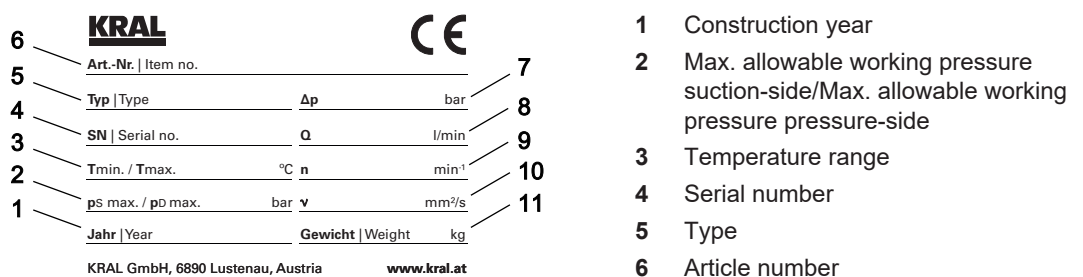

Fig. 2: Rating plate

- 1 Construction year
- 2 Max. allowable working pressure suction-side/Max. allowable working pressure pressure-side
- 3 Temperature range
- 4 Serial number
- 5 Type
- 6 Article number
- 7 Differential pressure
- 8 Nominal delivery rate
- 9 Rated speed
- 10 Nominal viscosity
- 11 Weight

## 4 Technical data

### 4.1 Operating limits

Parameter	Unit	EKL 11	EKL 12	EKL 13	EKS 11	EKS 12	EKS 13
Max. operating pressure							
<input type="checkbox"/> Pump unit	[bar]	6					
<input type="checkbox"/> Strainer + deaerator	[bar]	6					
<input type="checkbox"/> Shut-off devices	[bar]	6					
<input type="checkbox"/> Pressure maintaining valve	[bar]	–	6	6	–	6	6
Inlet pressure							
<input type="checkbox"/> max.	[bar]	6					
Temperature pumped liquid							
<input type="checkbox"/> min.	[°C]	-20					
<input type="checkbox"/> max.	[°C]	250					
Viscosity							
<input type="checkbox"/> min.	[mm <sup>2</sup> /s]	2					
<input type="checkbox"/> max.	[mm <sup>2</sup> /s]	10000					
Ambient temperature							
<input type="checkbox"/> min.	[°C]	-20					
<input type="checkbox"/> max.	[°C]	50					

Tab. 3: Operating limits

### 4.2 Required NPSH values

The required NPSH values of the pump depend on the size, the viscosity of the pumped liquid and the speed.

The NPSH values are available on the website of the manufacturer:

[www.kral.at/en/screw-pumps](http://www.kral.at/en/screw-pumps)

### 4.3 Sound pressure level

Guide values at 1 m distance, 1450 min<sup>-1</sup>, 10 bar

Size	Sound pressure level ±3 [dB(A)]		
	Pump	Motor	Pump unit
240 – 1000	50.0	42.0	51.0
1800 – 2300	52.0	44.0	54.0
3200 – 4000	55.0	50.0	56.0
6000	56.0	50.0	57.0

Tab. 4: Sound pressure level

## 4 Technical data

### 4.4 Output tables

#### 4.4 Output tables

Pump station EKL size		240	400	500	
Pump KFN size		5	7	10	
		Unit			
Engine power	[kW]	0.25	0.25	0.25	
Delivery rate at 6 mm <sup>2</sup> /s					
□ 50 Hz, 1450 rpm					
	□ 3 bar	[l/h]	210	336	462
	□ 6 bar	[l/h]	168	276	390
□ 60 Hz, 1750 rpm					
	□ 3 bar	[l/h]	276	432	588
	□ 6 bar	[l/h]	234	372	522
Filter area	[cm <sup>2</sup> ]	320			

Tab. 5: Power table EKL 240 - 500

Pump station EKL size		750	1000	1800	
Pump KFN size		7	10	15	
		Unit			
Engine power	[kW]	0.37	0.55	0.55	
Delivery rate at 6 mm <sup>2</sup> /s					
□ 50 Hz, 2900 rpm					
	□ 3 bar	[l/h]	804	1086	1662
	□ 6 bar	[l/h]	750	1020	1578
□ 60 Hz, 3400 rpm					
	□ 3 bar	[l/h]	966	1302	1980
	□ 6 bar	[l/h]	912	1236	1902
Filter area	[cm <sup>2</sup> ]	320			

Tab. 6: Power table EKL 750 - 6000

Pump station EKS size		240	400	500	
Pump KFN size		5	7	10	
		Unit			
Engine power	[kW]	0.25	0.25	0.25	
Delivery rate at 6 mm <sup>2</sup> /s					
□ 50 Hz, 1450 rpm					
	□ 3 bar	[l/h]	276	426	570
	□ 6 bar	[l/h]	264	408	546
□ 60 Hz, 1750 rpm					
	□ 3 bar	[l/h]	342	522	702
	□ 6 bar	[l/h]	330	504	678
Filter area	[cm <sup>2</sup> ]	320			

Tab. 7: Power table EKS 240 - 500



Pump station EKS size		750	1000	1800	2300	3200	4000	6000	
Pump KFN size		7	10	15	20	32	42	55	
Unit									
Engine power	[kW]	0.37	0.55	0.55	0.75	1.5	2.2	3.0	
Delivery rate at 6 mm <sup>2</sup> /s									
<input type="checkbox"/> 50 Hz, 2900 rpm									
<input type="checkbox"/> 3 bar	[l/h]	894	1200	1794	2358	3750	4992	6840	
<input type="checkbox"/> 6 bar	[l/h]	876	1176	1764	2322	3708	4938	6768	
<input type="checkbox"/> 60 Hz, 3400 rpm									
<input type="checkbox"/> 3 bar	[l/h]	1056	1416	2112	2778	4410	5880	8052	
<input type="checkbox"/> 6 bar	[l/h]	1038	1392	2088	2742	4368	5820	7974	
Filter area	[cm <sup>2</sup> ]	320				720			

Tab. 8: Power table EKS 750 - 6000

4.5 Mesh width strainer/filter

Options	Usage	Viscosity [mm <sup>2</sup> /s]	Mesh width [mm]
Strainer	Separation of coarse soiling during operation	< 20	0.25
		> 20	0.5
Commissioning strainer/ commissioning filter	Protection of the station during commissioning	–	0.02
Operating filter	Protection of the station during operation	–	Depending on pumped liquid

Tab. 9: Mesh width strainer/filter

4.6 Weights

The weight is specified on the rating plate.

5 Function description

5.1 Structure of standard version

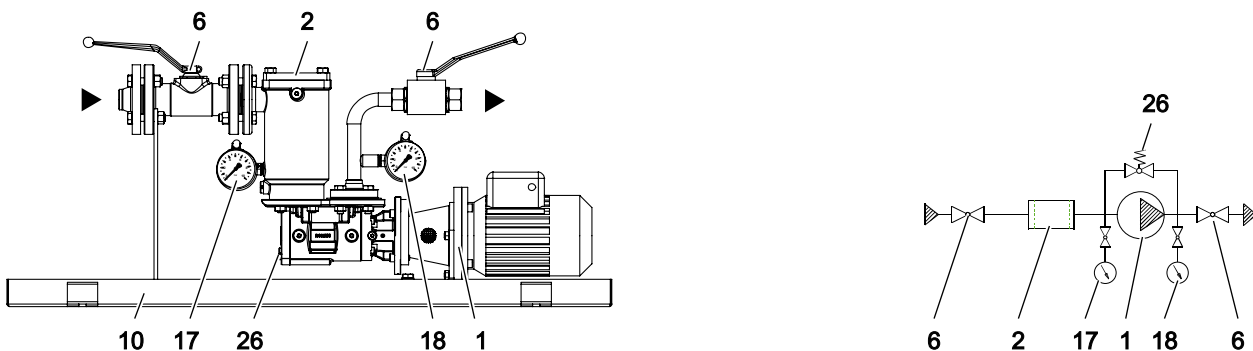

Fig. 3: EKL/EKS 11

## 5 Function description

### 5.2 Structure of special design

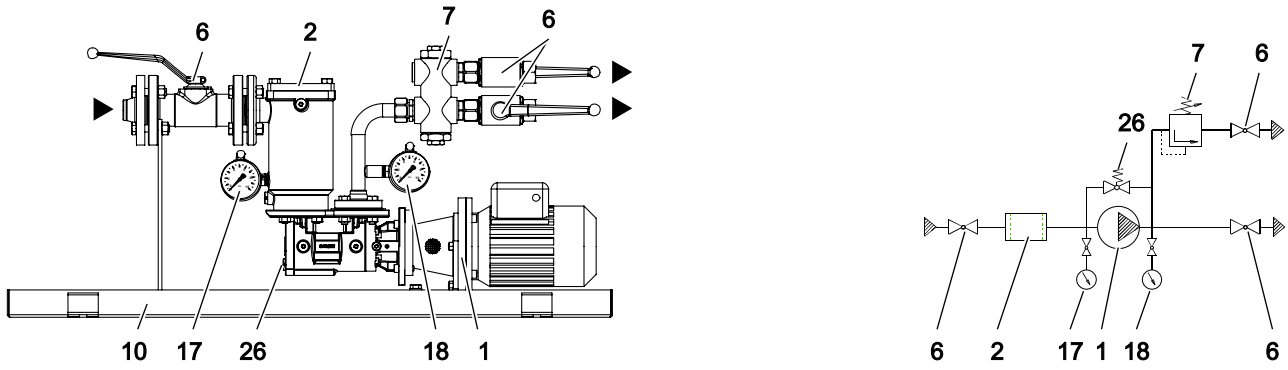

Fig. 4: EKL/EKS 12

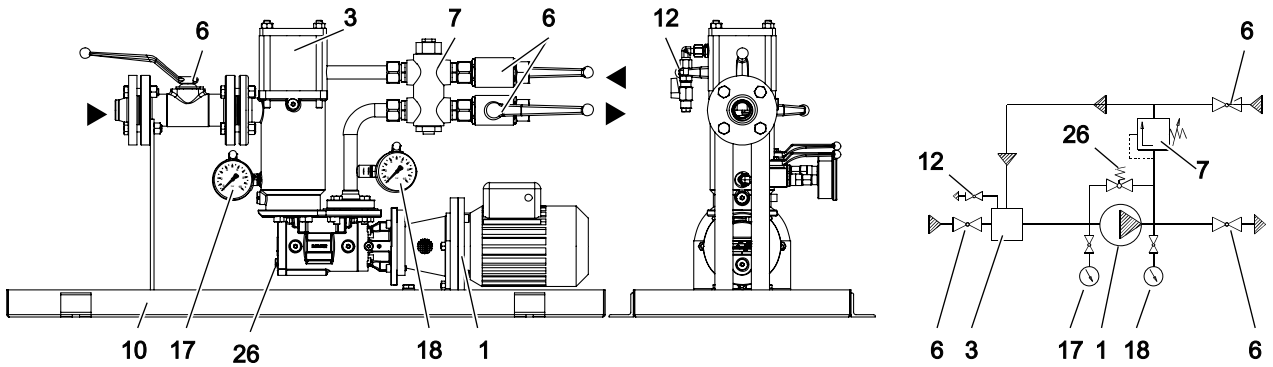

Fig. 5: EKL/EKS 13

- |   |                                    |    |                              |
|---|------------------------------------|----|------------------------------|
| 1 | Pump unit                          | 10 | Base frame                   |
| 2 | Strainer                           | 12 | Deaerator venting            |
| 3 | Deaerator with integrated strainer | 17 | Suction-side pressure gauge  |
| 6 | Ball valve                         | 18 | Pressure-side pressure gauge |
| 7 | Pressure maintaining valve         | 26 | Overflow valve pump          |

### 5.2 Structure of special design

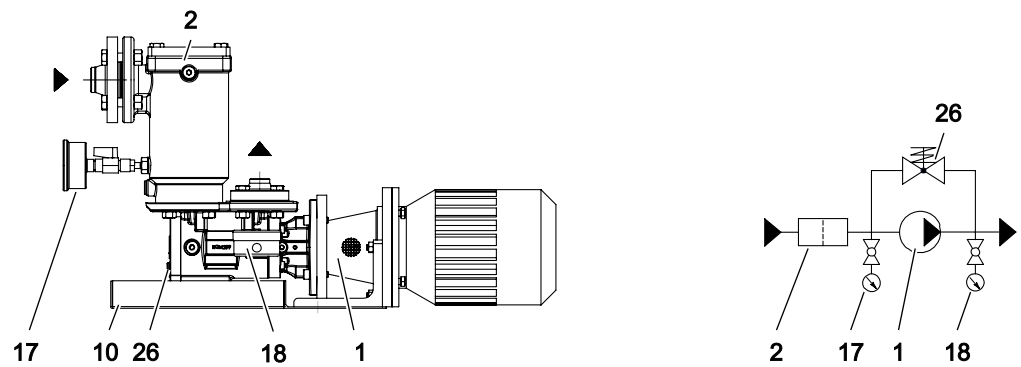

Fig. 6: EKS 11 special design

- |    |            |    |                              |
|----|------------|----|------------------------------|
| 1  | Pump unit  | 17 | Suction-side pressure gauge  |
| 2  | Strainer   | 18 | Pressure-side pressure gauge |
| 10 | Base frame | 26 | Overflow valve pump          |

### 5.3 Functional principle

The pump station of the EKL/EKS series is a fuel oil transfer pump station and in the basic module consists of a screw pump of the series KFN 1, large-area strainer 2, suction-side and pressure-side ball valves 6 as well as shut-off pressure gauges 17, 18 on the suction side and pressure side. The basic module can be extended with a pressure maintaining valve 7 and a deaerator with integrated strainer 3. The drawn oil flows through the suction-side shut-off devices and the strainer to the suction side of the pump which pumps the liquid into the pressure line. The suction-side pressure gauge shows the pressure between strainer and pump as well as the soiling of the strainer. The pressure-side pressure gauge is used to monitor operation. You can find detailed information in the associated pump operating instructions.

### 5.4 Pressure maintaining valve

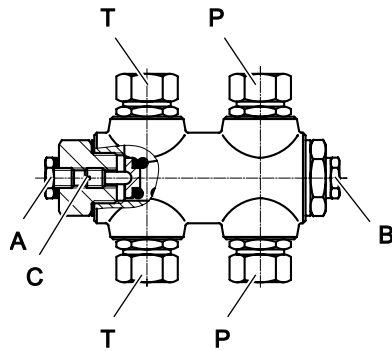

The pressure maintaining valve is used to regulate the pressure by means of an overflowing partial volume flow. The pressure maintaining valve is a directly controlled spring-loaded piston valve that keeps or limits the pressure prevailing in the pressure line **P** to an operating pressure or maximum pressure set by means of the pressure spring. The excess liquid is drained into the connection of the return line **T**. A flow rate in the pressure line that is too low, arising for example when a ball valve is closed, can result in overheating and damage to the pump. Pump operation with an overflow of the complete delivery rate for more than 45 seconds is therefore not permitted without prior consultation with the manufacturer.

The set pressure of the valve can be adjusted by means of an Allen key, ↪ During operation, Page 26.

### 5.5 Pulsation damper

As a mechanical regulating valve, the pressure maintaining valve has a certain sluggishness. Therefore rapid changes in the flow rate (for example usage of rapid switching valves, starting of the pump without soft start) and rigid pipe systems can result in brief pressure peaks. To avoid operating problems or damage to system components, a pulsation damper can be installed in the pipe system, ↪ Installation, removal, Page 17. As an alternative such a pulsation damper can also be mounted directly at the pump station. The pulsation damper is available from the manufacturer.

## 5 Function description

### 5.6 Expansion valve (optional)

#### 5.6 Expansion valve (optional)

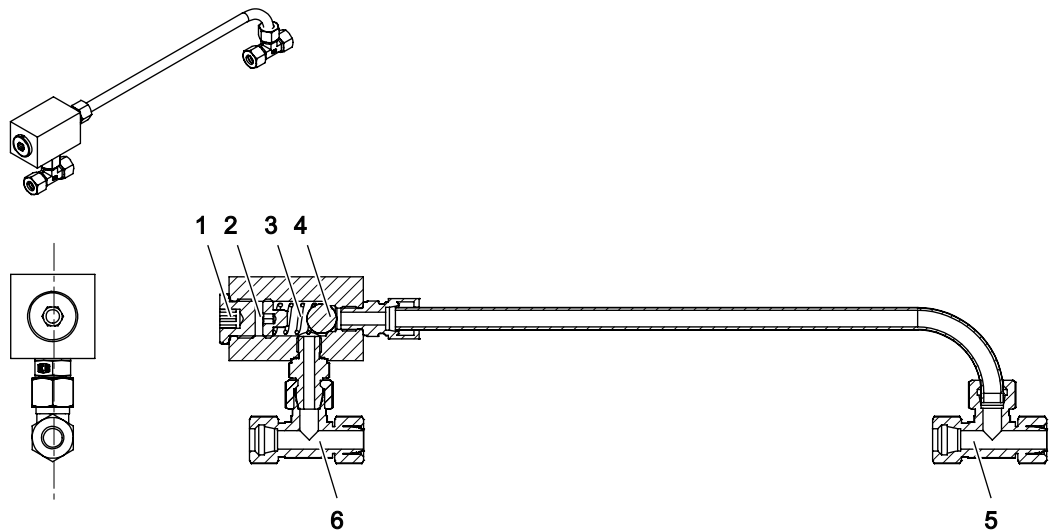

Fig. 7: Structure of expansion valve

- |   |                 |   |                         |
|---|-----------------|---|-------------------------|
| 1 | Screw plug      | 4 | Valve body              |
| 2 | Adjusting screw | 5 | Inflow from the station |
| 3 | Pressure spring | 6 | Overflow                |

When the station is switched off, thermal expansion of the fluid volume which is caused by heating up can result in an impermissibly high inner pressure. To prevent this a spring-loaded expansion valve is offered as an option, which relieves any overpressure arising in the station. This expansion valve is set in the factory to an opening pressure of 5 bar.

#### 5.7 Protection against soiling

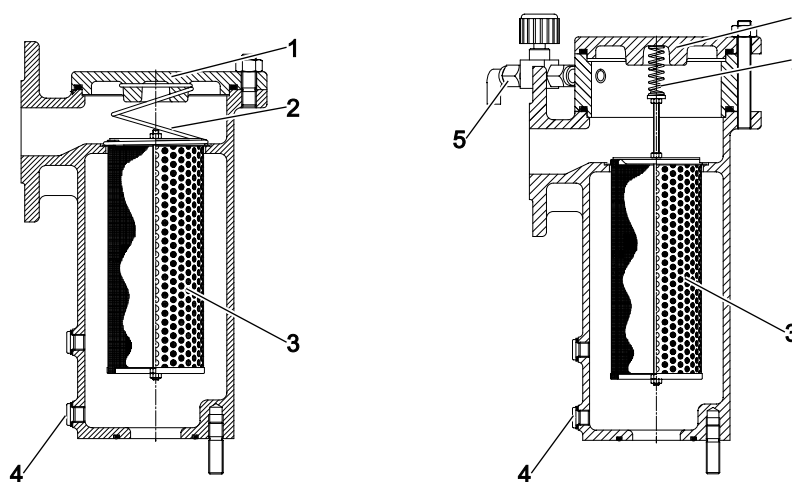



Fig. 8: Strainer (left) / Deaerator with integrated strainer (right)

- |   |                 |   |             |
|---|-----------------|---|-------------|
| 1 | Strainer cover  | 4 | Drain screw |
| 2 | Conical spring  | 5 | Venting     |
| 3 | Strainer insert |   |             |

The pump station is equipped with one or two strainers as standard. However, these are not capable of separating larger amounts of soiling occurring regularly or abrasive fine particles. If such operating conditions occur, the station has to be protected additionally by a correspondingly dimensioned operating filter. Very fine abrasive particles can, however, not be held back by the operating filter and cause increased wear to the pumps. Alternatively the strainers can be replaced during commissioning by fine-meshed commissioning strainers. A further possibility is the use of an external commissioning filter. The strainer inserts are made of metal and can be cleaned and reused,  Servicing, Page 29.

### 5.8 Options for standard version

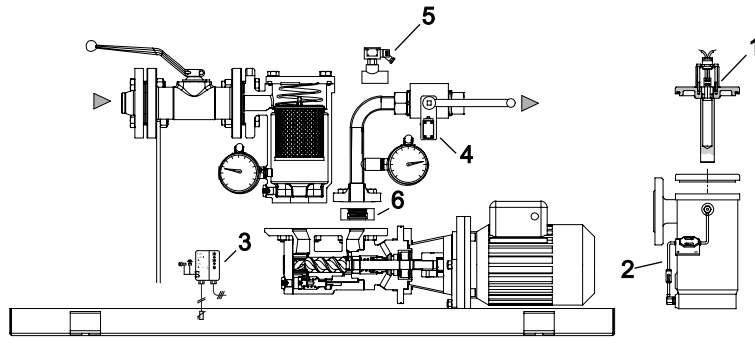

Fig. 9: EKL/EKS 11

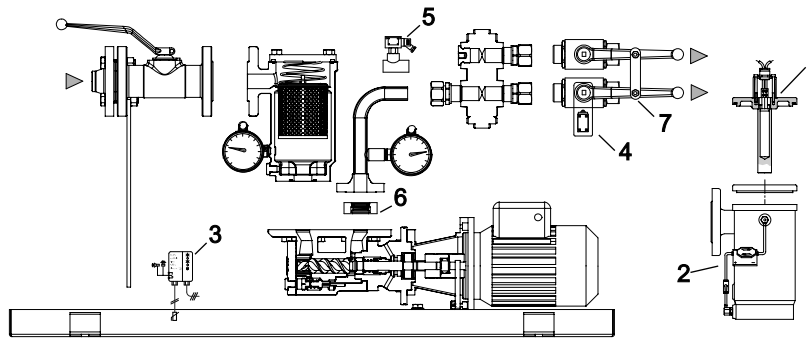

Fig. 10: EKL/EKS 12

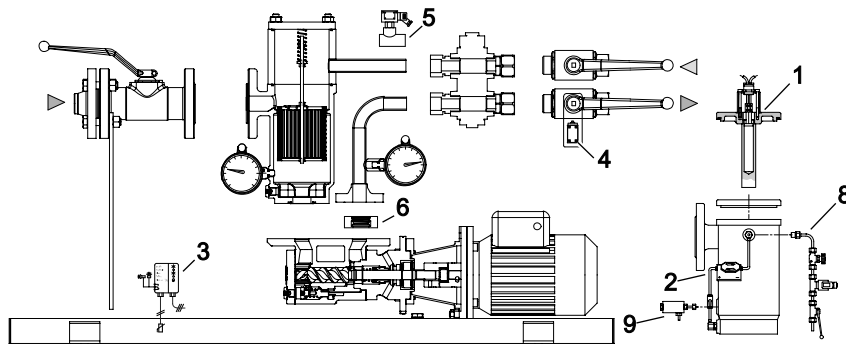

Fig. 11: EKL/EKS 13

- |   |                                       |   |                                |
|---|---------------------------------------|---|--------------------------------|
| 1 | Electrical heating system strainer    | 6 | Non-return valve pressure-side |
| 2 | Differential pressure indicator       | 7 | Override switch for ball valve |
| 3 | Leak oil monitoring                   | 8 | Venting with time control      |
| 4 | Ball valve with limit switch          | 9 | Expansion valve                |
| 5 | Pressure monitor in the pressure line |   |                                |

### 5.9 Options for special design

- Leak oil monitoring

## 6 Transportation, storage

### 5.10 Heating system (optional)

#### 5.10 Heating system (optional)

##### 5.10.1 Possible types of heating

The pump station can optionally be equipped with a heating system. The manufacturer recommends a heating system at high-viscosity pumped liquids that do not flow sufficiently if not heated. This can result in excessive wattage or in problems arising through cavitation or sealing.

Possible types of heating:

- Electrical heating system pump
- Electrical heating system strainer

##### 5.10.2 Electrical heating system

The output of the heating elements corresponds to the radiation and convection losses of the station in the required temperature range so that overheating is not possible.

###### Electrical heating system pump

Detailed information is provided in the associated operating instructions of the pump.

###### Electrical heating system strainer

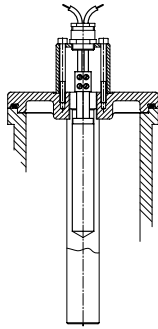

The heating element is inserted into the strainer chamber and fastened with a special cover. The oil heated up in the strainer also enters the pump and thus ensures reliable starting.

Parameter	Unit	Value
Voltage	[V]	230
Heating output	[W]	180
Wire cross-section	[mm <sup>2</sup> ]	2 x 1

Tab. 10: Operating data

## 6 Transportation, storage

### 6.1 Dangers during transportation



#### The following safety instructions must be observed

- Have all work only carried out by authorized qualified personnel.
- A crane operator and transport personnel are required for transportation (2 persons).
- Use intact and correctly dimensioned hoisting equipment.
- Ensure that the means of transport is in a flawless state.
- Ensure that the centre of gravity of the load is taken into consideration.
- Do not stand under raised loads.
- Cordon off the danger zone and ensure that unauthorized persons cannot enter the danger zone.

### 6.2 Dangers during storage



#### The following safety instructions must be observed:

- Observe the storage conditions.

### 6.3 Unpacking and checking the state of delivery

Personnel qualification:	<input type="checkbox"/> Trained personnel
1. ➤	Upon delivery unpack the pump station and check it for damage during transportation.
2. ➤	Report damage during transportation immediately to the manufacturer.
3. ➤	Dispose of packaging material in accordance with the locally applicable regulations.

### 6.4 Transporting the pump station

Personnel qualification:	<input type="checkbox"/> Transport personnel
Personal protective equipment:	<input type="checkbox"/> Work clothing
	<input type="checkbox"/> Protective helmet
	<input type="checkbox"/> Protective gloves
	<input type="checkbox"/> Safety boots
Aids:	<input type="checkbox"/> Mobile crane, forklift, hoisting equipment <input type="checkbox"/> Traverse



#### **⚠ WARNING**

##### **Risk of injury and damage to equipment through falling and toppling parts.**

- ▶ Use intact and correctly dimensioned hoisting equipment in accordance with the total weight to be transported.
- ▶ Select the lift points for the hoisting equipment in accordance with the centre of gravity and the weight distribution.
- ▶ Use at least two load ropes.
- ▶ Do not stand under raised loads.

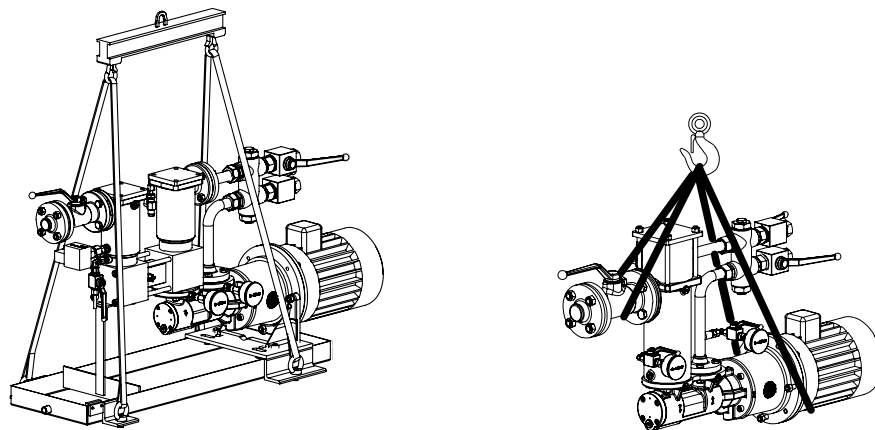

Fig. 12: Fastening of hoisting equipment - principle diagram

- Secure the hoisting equipment to the pump station and lift the pump station using the crane.

### 6.5 Storing the pump station

During the test run, the internal components of the pump station are wetted with test oil, which has a preservative effect. The pipe connections are fitted with protective covers. Unless otherwise specified, the outer parts of the pump station are preserved with a single-coat PU-based two-component paint. The preservative applied at the factory will protect the pump station for about six weeks, if it is stored in a dry and clean location.

The manufacturer offers a long-term preservation for storage times of up to 60 months. The pump station is additionally packed in hermetically sealing anti-corrosion paper.

Personnel qualification:	<input type="checkbox"/> Transport personnel
Aids:	<input type="checkbox"/> Mobile crane, forklift, hoisting equipment

## 7 Preservation

### 7.1 Preservation table

#### ATTENTION

##### Damage to equipment and corrosion if stored improperly and during longer standstills.

- ▶ Protect the pump station against damage, heat, sunlight, dust, moisture and magnetic fields.
- ▶ Protect against corrosion during longer standstill.
- ▶ Observe measures for storing and preservation.

1. ▶ Store cool and dry and protect against sunlight.
2. ▶ Ensure that the anti-corrosion paper is not damaged.
3. ▶ Observe the intervals for preservation ↪ Preservation, Page 16.

## 7 Preservation

### 7.1 Preservation table

Preservation has to be carried out additionally under the following conditions:

Type of delivery	Condition
Standard delivery	<input type="checkbox"/> Storage time exceeding six weeks <input type="checkbox"/> Unfavourable storage conditions such as high humidity, salty air, etc.
Delivery with long-term preservation	<input type="checkbox"/> Opened or damaged packaging

Tab. 11: Conditions for additional preservation

### 7.2 Preserving the inner surfaces

Personnel qualification:	<input type="checkbox"/> Trained personnel
Personal protective equipment:	<input type="checkbox"/> Work clothing <input type="checkbox"/> Protective gloves <input type="checkbox"/> Safety boots
Aids:	<input type="checkbox"/> Preservative (acid-free and resin-free oil)

1. ▶ Close the pipe connections of the station.
2. ▶ Open the strainer cover. Fill the preservative into the strainer chamber, while slowly turning the pump at the fan impeller of the motor in the direction of rotation. Do not fill the strainer completely, but leave approx. 2 cm height empty. Close the strainer cover.
3. ▶ After about six months storage check the filling level of the preservative and if necessary top up.

### 7.3 Preserving the outer surfaces

Personnel qualification:	<input type="checkbox"/> Trained personnel
Personal protective equipment:	<input type="checkbox"/> Work clothing <input type="checkbox"/> Face protection <input type="checkbox"/> Protective gloves <input type="checkbox"/> Safety boots
Aids:	<input type="checkbox"/> Calcium complex grease (for example TEVI-ER® GREASE WAVE 100 with adhesive additive) <input type="checkbox"/> Castrol Rustilo DWX 21 or other preservative offering comparable protection

1. ▶ Brush calcium complex grease corrosion protection (for example TEVI-ER® FETT WAVE 100 with adhesive additive) to the mounting surfaces.
2. ▶ Brush or spray preservative (for example Castrol Rustilo DWX 21) onto the process connections and remaining plain and unpainted parts.
3. ▶ At intervals of about six months check the preservation and if necessary repeat.



## 7.4 Removing the preservation

Personnel qualification:	<input type="checkbox"/> Trained personnel
Personal protective equipment:	<input type="checkbox"/> Work clothing <input type="checkbox"/> Protective gloves <input type="checkbox"/> Safety boots
Aids:	<input type="checkbox"/> Solvent <input type="checkbox"/> Steam-jet cleaning device with wax-dissolving additives <input type="checkbox"/> Collection tank



### CAUTION

#### Risk of injury through discharging preservative.

- ▶ Wear personal protective equipment during all the work.
- ▶ Collect any discharging preservative safely and dispose of it in an environmentally compatible manner in accordance with the applicable local regulations.

1. ➤ Clean the outside of the pump station with solvents, if necessary using a steam-jet cleaning device.
2. ➤ Remove the strainer cover carefully in order to reduce any pressure that may exist in the pump station.
3. ➤ Drain the pump station, collecting the preservative in a collection tank.
4. ➤ To remove the residual preservative, flush the pump station with the pumped liquid.

## 8 Installation, removal

### 8.1 Dangers during installation



#### The following safety instructions must be observed strictly:

- Have all work carried out only by authorized qualified personnel.
- Before installation ensure that the operating limits, NPSH values and ambient conditions are observed.
- Observe the tightening torques ↪ Appendix, Page 38.
- Ensure that all the components can be accessed and that maintenance work can be carried out easily.

### 8.2 Dangers during removal



#### The following safety instructions must be observed strictly:

- Have all work carried out only by authorized qualified personnel.
- Before beginning work, let the pump station cool down to the ambient temperature.
- Collect any discharging pumped liquid safely and dispose of it in an environmentally compatible manner in accordance with the applicable local regulations.
- Ensure that the collection tank for discharging pumped liquids is sufficiently large.

### 8.3 Mounting the pump station

**Note** Soiling in the pipe system impairs the service life of the pump station. If the pipe system is flushed using the pump station during the initial commissioning, an additional commissioning filter has to be installed temporarily before the pump station. Alternatively the strainers supplied as standard can be replaced during commissioning by fine-meshed commissioning strainers.

Personnel qualification:	<input type="checkbox"/> Transport personnel <input type="checkbox"/> Fitter
Personal protective equipment:	<input type="checkbox"/> Work clothing <input type="checkbox"/> Protective gloves <input type="checkbox"/> Safety boots
Aids:	<input type="checkbox"/> Mobile crane, forklift, hoisting equipment

## 8 Installation, removal

### 8.4 Protecting the pump station against pressure peaks



#### **WARNING**

**Risk of injury and damage to equipment through falling and toppling parts.**

- ▶ Only fasten the pump station on a stable bearing underground.
- ▶ Ensure that fastening elements and pipings are fastened sufficiently.

#### **ATTENTION**

**Damage to device through impurity in the pipe system.**

- ▶ During welding work attach protective covers in front of the connecting flanges.
- ▶ Ensure when welding that welding beads and abrasive dust cannot get into the pipe system and the pump station.
- ▶ Ensure that a commissioning filter is installed when the pipe system is flushed and cleaned using the pump.

Requirement:

- ✓ Pump station connections protected against soiling, for example by using the protective cover mounted in the factory
1. ▶ Bring the pump station into the installation position.
  2. ▶ Fasten the pump station with fastening elements securely on the ground. The pump station including oil pan must rest fully on a base frame or on the floor in order to avoid vibrations.

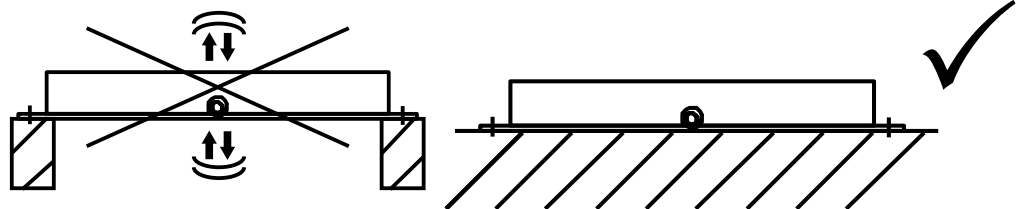

Fig. 13: Securing the oil pan

3. ▶ After the connecting work clean the pipe system thoroughly ↪ Commissioning, Page 23.

### 8.4 Protecting the pump station against pressure peaks

#### **ATTENTION**

**Damage to the plant components through pressure peaks.**

- ▶ Use pulsation damper.

**Note** The pulsation damper is available as an option from the manufacturer.

- ▶ Install the pulsation damper in the pipe system.
- or-
- ▶ Mount the pulsation damper on the pump station.

## 8.5 Removing the pump station

Personnel qualification:	<input type="checkbox"/> Transport personnel <input type="checkbox"/> Fitter <input type="checkbox"/> Electrician
Personal protective equipment:	<input type="checkbox"/> Work clothing <input type="checkbox"/> Protective helmet <input type="checkbox"/> Face protection <input type="checkbox"/> Protective gloves <input type="checkbox"/> Safety boots
Aids:	<input type="checkbox"/> Mobile crane, forklift, hoisting equipment <input type="checkbox"/> Solvents or industrial cleaners suitable for the pumped liquid <input type="checkbox"/> Collection tank



### **! DANGER**

#### **Risk of death resulting from electric shock.**

- ▶ Ensure that the electrical power supply is de-energized and is secured against being switched back on.
- ▶ Observe the operating instructions of the electrical components.



### **! DANGER**

#### **Risk of death resulting from falling load.**

- ▶ Use intact and correctly dimensioned hoisting equipment.
- ▶ Ensure that the crane and hoisting equipment are in a flawless state.
- ▶ Do not stand under raised loads.
- ▶ Take the centre of gravity into account and secure the load against tilting.
- ▶ A crane operator and transport personnel are required for transportation (2 persons).



### **! DANGER**

#### **Risk of death through emitted pumped liquid.**

Pumped liquids can be hot, poisonous, combustible and caustic and can spray out under high pressure.

- ▶ Wear personal protective clothing during all the work. Ensure face protection.
- ▶ Before beginning work, let the pump station cool down to the ambient temperature.
- ▶ Ensure that the pump station is depressurized.
- ▶ Collect any discharging pumped liquid safely and dispose of it in an environmentally compatible manner in accordance with the applicable local regulations.

Requirement:

- ✓ Pump station and pumped liquid cooled down to the ambient temperature
- 1. ▶ Ensure that the pump station is deenergized and is secured against being switched back on.
- 2. ▶ Ensure that the pump station is depressurized.
- 3. ▶ Disconnect the pump station from the pipe system and drain it. Collect any liquids that are emitted.
- 4. ▶ Dismantle the pump station on site or transport it to a suitable site. Take the information on transportation into account.

9 Connection

9.1 Dangers during connection work



- The following safety instructions must be observed strictly:**
- Have all work on the pump station and pipe system only carried out by authorized qualified personnel.
  - Ensure that impurities cannot get into the pump station and pipe system.
  - Ensure that mechanical connections are mounted stress-free.
  - Observe the tightening torques.
  - Have all the work on the electrical equipment only carried out by electricians.
  - Before commissioning ensure correct earthing, equipotential bonding and overcurrent protection.
  - Before beginning work on the pump station ensure that the electrical power supply is deenergized and is secured against being switched back on.
  - If the insulation of the electrical cables or wires is damaged, disconnect the power supply immediately.

9.2 Connecting the pump station to the pipe system

9.2.1 Setup of the suction line

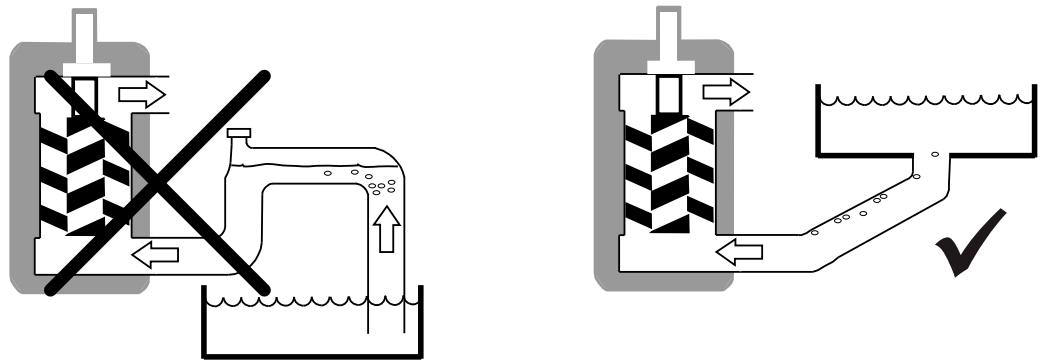

Fig. 14: Setup of the suction line

Lay the suction line hermetically sealed. If preheated heating oils are pumped, install the tank above the station and lay the suction line without siphon or pipe elbow.

9.2.2 Flange connection

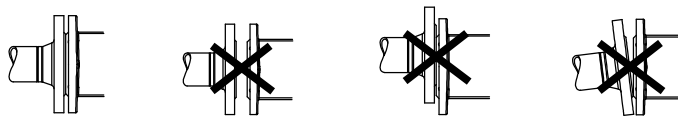

Fig. 15: Pipe connection

Personnel qualification:	<input type="checkbox"/> Fitter
Personal protective equipment:	<input type="checkbox"/> Work clothing <input type="checkbox"/> Protective gloves <input type="checkbox"/> Protective helmet <input type="checkbox"/> Safety boots
Aids:	<input type="checkbox"/> Mobile crane, forklift, hoisting equipment <input type="checkbox"/> Torque wrench

**ATTENTION****Damage to device through impurity in the pipe system.**

- ▶ During welding work attach protective covers in front of the connecting flanges.
- ▶ Ensure when welding that welding beads and abrasive dust cannot get into the pipe system and the pump station.
- ▶ Ensure that a commissioning filter is installed when the pipe system is flushed and cleaned using the pump.

**ATTENTION****Damage to device through mechanical stress.**

- ▶ Ensure that the pump station is mounted free of mechanical stresses in the pipe system.
- ▶ Observe the tightening torques.

1. ▶ Attach protective covers in front of the connecting flanges before welding work.
2. ▶ Place the piping in position and support the weight of the piping. Do not use the pump station as a support for connected piping.
3. ▶ Check the linear, height and angular offset and correct if necessary.  
⇒ If the screws tighten easily, this is a sure sign that the installation is stress-free.
4. ▶ Tighten the connecting screws.

**9.2.3 Pipe screwed connection**

Personnel qualification:	<input type="checkbox"/> Fitter
Personal protective equipment:	<input type="checkbox"/> Work clothing <input type="checkbox"/> Protective gloves <input type="checkbox"/> Protective helmet <input type="checkbox"/> Safety boots
Aids:	<input type="checkbox"/> Mobile crane, forklift, hoisting equipment

**ATTENTION****Damage to device through impurity in the pipe system.**

- ▶ During welding work attach protective covers in front of the connecting flanges.
- ▶ Ensure when welding that welding beads and abrasive dust cannot get into the pipe system and the pump station.
- ▶ Ensure that a commissioning filter is installed when the pipe system is flushed and cleaned using the pump.

**ATTENTION****Damage to device through mechanical stress.**

- ▶ Ensure that the pump station is mounted free of mechanical stresses in the pipe system.
- ▶ Observe the tightening torques.

## 9 Connection

### 9.3 Connecting the pump station to the power supply

**Note** The progressive ring can only be used once.

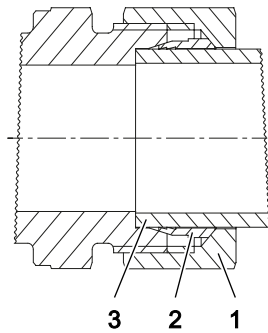

Fig. 16: Pipe screwed connection

1. ➤ Apply lubricating oil lightly to the progressive ring **2** and pipe **3**.
2. ➤ Slide the union nut **1** and progressive ring **2** over the pipe end. Ensure that the direction of the progressive ring is correct in the process.
3. ➤ Screw the union nut lightly in by hand. While doing so, press the pipe against the stop in the internal cone.
4. ➤ Tighten the union nut. The pipe may not turn as well in the process.

### 9.3 Connecting the pump station to the power supply

Personnel qualification:	<input type="checkbox"/> Electrician
Personal protective equipment:	<input type="checkbox"/> Work clothing <input type="checkbox"/> Protective gloves <input type="checkbox"/> Safety boots



#### **⚠ DANGER**

##### **Risk of death resulting from electric shock.**

- ▶ Ensure that the electrical power supply is de-energized and is secured against being switched back on.
- ▶ Before commissioning ensure correct grounding and equipotential bonding.
- ▶ Observe the operating instructions of the electrical components.

1. ➤ Carefully earth the base frames with the screwing.
2. ➤ Connect the electrical components of the pump station in accordance with the corresponding operating instructions.
3. ➤ When connecting the pump station to the complete system continue equipotential bonding.

## 10 Operation

### 10.1 Dangers during operation



#### The following safety instructions must be observed strictly:

- Have all work carried out only by authorized qualified personnel.
- Before commissioning ensure that a safety valve has been installed in the pressure-side pipe system to protect the pump station.
- Before commissioning, make sure that the suction line and pump station are filled.
- Pumped liquids can be hot, poisonous, combustible and caustic. Use corresponding protective equipment.
- Observe the operating instructions of the pump and the further components.
- Ensure that the pump station is only operated within the operating limits.
- Ensure that during cooling down or heating up the pump station is only subjected to slow temperature changes.
- Ensure that existing safety equipment is not bypassed or activated during operation.
- Before decommissioning ensure that the electrical power supply is deenergized and is secured against being switched back on.

### 10.2 Commissioning

#### 10.2.1 Cleaning the pipe system

**Note** Soiling in the pipe system impairs the service life of the pump station. If the pipe system is flushed using the pump station during the initial commissioning, an additional commissioning filter has to be installed temporarily before the pump station. Alternatively the strainers supplied as standard can be replaced during commissioning by fine-meshed commissioning strainers.

Personnel qualification:	<input type="checkbox"/> Fitter
Personal protective equipment:	<input type="checkbox"/> Work clothing <input type="checkbox"/> Protective gloves <input type="checkbox"/> Protective helmet <input type="checkbox"/> Safety boots

### ATTENTION

#### Damage to device through impurity in the pipe system.

- ▶ During welding work attach protective covers in front of the connecting flanges.
- ▶ Ensure when welding that welding beads and abrasive dust cannot get into the pipe system and the pump station.
- ▶ Ensure that a commissioning filter is installed when the pipe system is flushed and cleaned using the pump.

### ATTENTION

#### Damage to equipment through additional pressure loss in the commissioning filter/commissioning strainer.

- ▶ Calculate the flow resistance and determine the remaining pump intake.
- ▶ Monitor the suction-side pressure.
- ▶ Check the commissioning filter/commissioning strainer regularly.

#### Requirement:

✓ If required, commissioning filter/commissioning strainer installed (mesh width 0.02 mm)

1. ▶ Clean the complete pipe system before commissioning in order to protect the pump station.
2. ▶ Flush the pipe system at least 50 – 100 hours.

### 10.2.2 Filling and venting the pump station

#### Possibilities

There are two possible ways to fill the pump station:

- Via the suction connection or pressure connection
- Via the strainers

#### Filling and venting the pump station via the suction connection or pressure connection

Personnel qualification:	<input type="checkbox"/> Fitter
Personal protective equipment:	<input type="checkbox"/> Work clothing <input type="checkbox"/> Protective gloves <input type="checkbox"/> Protective helmet <input type="checkbox"/> Safety boots <input type="checkbox"/> Face protection
Aids:	<input type="checkbox"/> Collection tank



#### DANGER

##### Risk of death through emitted pumped liquid.

Pumped liquids can be hot, poisonous, combustible and caustic and can spray out under high pressure.

- ▶ Observe the operating instructions of the pump.
- ▶ Wear personal protective clothing during all the work. Ensure face protection.
- ▶ Collect any discharging pumped liquid safely and dispose of it in an environmentally compatible manner in accordance with the applicable local regulations.

1. ➤ If a pumped liquid is available at the suction side or the pressure side, open the respective shut-off valve and fill the station.
2. ➤ Vent the pump and filter. Observe the associated operating instructions while doing so.

#### Filling and venting the pump station via the strainers

Personnel qualification:	<input type="checkbox"/> Fitter
Personal protective equipment:	<input type="checkbox"/> Work clothing <input type="checkbox"/> Protective gloves <input type="checkbox"/> Protective helmet <input type="checkbox"/> Safety boots <input type="checkbox"/> Face protection
Aids:	<input type="checkbox"/> Collection tank



#### WARNING

##### Risk of injury through emitted pumped liquid.

Pumped liquids can be hot, poisonous, combustible and caustic.

- ▶ Wear personal protective clothing during all the work. Ensure face protection.
- ▶ Collect any discharging pumped liquid safely and dispose of it in an environmentally compatible manner in accordance with the applicable local regulations.

1. ➤ Dismantle the strainer cover.
2. ➤ Fill the pumped liquid into the strainer until it is filled completely.
3. ➤ Vent the pump and strainer. Observe the associated operating instructions while doing so.
4. ➤ Fill the strainer chamber again with pumped liquid.
5. ➤ Mount the strainer cover.



### 10.2.3 Checking the direction of rotation

The direction of rotation and the flow direction are indicated by arrows on the pump. The direction of rotation of the motor specifies the direction of rotation of the pump. That is to say, the fan impeller of the motor must rotate in the direction in which the arrow on the pump is pointing to indicate direction of rotation.

➔ For information on checking the direction of rotation please refer to the pump operating instructions.

### 10.2.4 Commissioning the pump station

Personnel qualification:	<input type="checkbox"/> Fitter <input type="checkbox"/> Electrician
Personal protective equipment:	<input type="checkbox"/> Work clothing <input type="checkbox"/> Protective helmet <input type="checkbox"/> Protective gloves <input type="checkbox"/> Safety boots <input type="checkbox"/> Face protection
Aids:	<input type="checkbox"/> Collection tank



#### **WARNING**

##### **Risk of injury through emitted pumped liquid.**

Pumped liquids can be hot, poisonous, combustible and caustic.

- ▶ Wear personal protective clothing during all the work. Ensure face protection.
- ▶ Collect any discharging pumped liquid safely and dispose of it in an environmentally compatible manner in accordance with the applicable local regulations.

#### **ATTENTION**

##### **Dry running can damage pump equipment.**

- ▶ Ensure that the pump and the connected pipe system are filled properly.
- ▶ If the pump does not deliver after 10 – 15 seconds, abort commissioning.

Requirement:

- ✓ Pump station set up and connected correctly
  - ✓ Motors connected correctly
  - ✓ Pipe system is free of impurities
  - ✓ Pump station filled
  - ✓ Shut-off devices in the suction line and pressure line opened
  - ✓ All connections are sealed
1. ➔ Switch on the pump station.  
⇒ The pump station delivers when the pressure on the pressure side of the pump station rises.
  2. ➔ If the pump station does not deliver after 10–15 seconds of operation, abort commissioning, eliminate the cause of the fault and only then continue the commissioning procedure. Take the information from the fault table into account, ➔ Troubleshooting, Page 33.
  3. ➔ Run the pump station for a few minutes to allow the pipe system to vent fully.  
⇒ The pipe system is fully vented when the pump operating noise is smooth and a pressure gauge on the pressure side shows no more fluctuations.
  4. ➔ Check the function of the overflow valve, see the pump operating instructions.

## 10 Operation

### 10.3 During operation

#### 10.2.5 Venting the deaerator (optional)

The deaerator is a container above the strainer in which gas particles from the medium are collected. The gas can be discharged via the screwed-on ball valve to prevent cavitation.

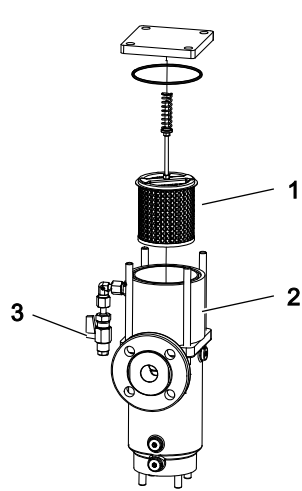

- 1 Strainer
- 2 Deaerator
- 3 Ball valve

➔ Bleed the deaerator twice an hour during commissioning.

### 10.3 During operation

#### 10.3.1 Checking the operating pressure

Personnel qualification:  Trained personnel

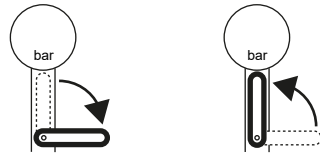

Fig. 17: Pressure gauge shut-off valves closed/open - principle diagram

## ATTENTION

**Leak in the pressure gauge through permanently opened pressure gauge shut-off valve.**

- ▶ Close the pressure gauge shut-off valve immediately after completing reading.

1. ➔ Open the pressure gauge shut-off valve.
2. ➔ Read the operating pressure and close the pressure gauge shut-off valve.

#### 10.3.2 Adjust overflow valve and test function

➔ Check the setting of the overflow valve, see the pump operating instructions.

#### 10.3.3 Setting the pressure maintaining valve

Personnel qualification:  Trained personnel

Aids:  Allen key



## CAUTION

**Damage to the overflow valve of the pump through permanent opening.**

- ▶ The maximum pressure: of the pressure maintaining valve must always lie under the opening pressure of the overflow valve.

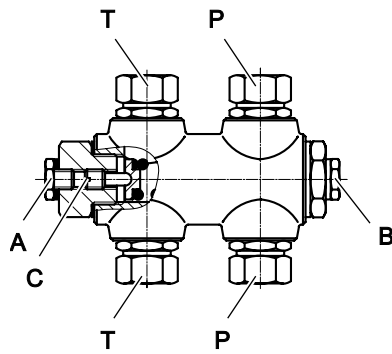

1. ➔ Remove the screw plug **A**.
2. ➔ Switch on the station and set the desired pressure by turning the setting screw **C**. If a pressure gauge does not exist on the system side, this can be connected to the pressure gauge connection **B**.
3. ➔ Screw the screw plug **A** back in.

#### 10.3.4 Switching off the pump station

Personnel qualification:	<input type="checkbox"/> Trained personnel
--------------------------	--

### ATTENTION

#### Seal damage through pressurizing during standstill.

- ▶ Ensure that the maximum permissible system pressure is not exceeded.

1. ➔ Switch off the motors.
2. ➔ Close the pressure- and suction-side shut-off devices.

## 10.4 Decommissioning

### 10.4.1 Taking the pump station out of operation

Personnel qualification:	<input type="checkbox"/> Fitter <input type="checkbox"/> Electrician
Personal protective equipment:	<input type="checkbox"/> Work clothing <input type="checkbox"/> Protective gloves <input type="checkbox"/> Safety boots <input type="checkbox"/> Face protection
Aids:	<input type="checkbox"/> Collection tank



### ⚠ WARNING

#### Risk of injury through emitted pumped liquid.

Pumped liquids can be hot, poisonous, combustible and caustic.

- ▶ Wear personal protective clothing during all the work. Ensure face protection.
- ▶ Collect any discharging pumped liquid safely and dispose of it in an environmentally compatible manner in accordance with the applicable local regulations.

➔ Carry out the following measures during operation interruptions.

Scope of the operation interruption	Measure
<input type="checkbox"/> Pump station shut down for longer period	➔ Depending on the pumped liquid
<input type="checkbox"/> Pump station drained	➔ Close the pressure- and suction-side shut-off devices.

# 11 Maintenance

## 10.5 Recommissioning

Scope of the operation interruption	Measure
<input type="checkbox"/> Pump station dismantled	—> Disconnect the motors from the power supply and secure against being switched back on.
<input type="checkbox"/> Pump station stored	—> Observe measures for storing and preservation ↪ Transportation, storage, Page 14.

Tab. 12: Measures during operation interruptions

Behaviour of the pumped liquid	Duration of the operation interruption	
	Short	Long
<input type="checkbox"/> Solids sediment	—> Flush the pump station.	—> Flush the pump station.
<input type="checkbox"/> Congealed/frozen <input type="checkbox"/> No corrosive burden	—> Heat or drain the pump station.	—> Drain the pump station.
<input type="checkbox"/> Congealed/frozen <input type="checkbox"/> Corrosive burden	—> Heat or drain the pump station.	1. —> Drain the pump station. 2. —> Preserve the pump station.
<input type="checkbox"/> Remains liquid <input type="checkbox"/> No corrosive burden	–	–
<input type="checkbox"/> Remains liquid <input type="checkbox"/> Corrosive burden	–	1. —> Drain the pump station. 2. —> Preserve the pump station.

Tab. 13: Measures depending on the behaviour of the pumped liquid

—> Drain the pump station via the pressure line, suction line, vent screws and screw plugs.

## 10.5 Recommissioning

### 10.5.1 Recommissioning the pump station

—> Carry out all the steps as for the commissioning process, ↪ Commissioning, Page 23.

# 11 Maintenance

## 11.1 Dangers during maintenance



**The following safety instructions must be observed strictly:**

- Have all work carried out only by authorized qualified personnel.
- Before beginning work, let the pump station cool down slowly to the ambient temperature. Avoid rapid temperature changes.
- Pumped liquids can be hot, poisonous, combustible and caustic. Use corresponding protective equipment.
- Collect any discharging pumped liquid safely and dispose of it in an environmentally compatible manner in accordance with the applicable local regulations.
- Ensure that the collection tank for discharging pumped liquids is sufficiently large.
- Observe the operating instructions and data sheets of the components.

## 11.2 Required maintenance

The service life depends on the observance of the operating conditions of the pump station and the requirements from the operating instructions of the components.

Component	Required maintenance	Cycle
Pump station	<input type="checkbox"/> Visual inspection <input type="checkbox"/> Acoustic inspection	4 weeks
Strainer	<input type="checkbox"/> Visual inspection <input type="checkbox"/> If required, clean	4 weeks

Component	Required maintenance	Cycle
Deaerator	<input type="checkbox"/> Venting	When necessary
Overflow valve	<input type="checkbox"/> Functional test ↪ Operation, Page 23	≤ 5 years

Tab. 14: Required maintenance

### 11.3 Maintaining the pump station

Personnel qualification:	<input type="checkbox"/> Fitter
Personal protective equipment:	<input type="checkbox"/> Work clothing <input type="checkbox"/> Protective gloves <input type="checkbox"/> Safety boots

1. ➤ Check the pump station visually and acoustically every four weeks.
2. ➤ If there are signs of wear, eliminate the cause ↪ Servicing, Page 29.
3. ➤ Observe the additional operating instructions of the pumps and optional components.

### 11.4 Maintaining the strainers

Personnel qualification:	<input type="checkbox"/> Fitter
Personal protective equipment:	<input type="checkbox"/> Work clothing <input type="checkbox"/> Protective gloves <input type="checkbox"/> Safety boots

1. ➤ Check the strainers visually and acoustically every four weeks.
2. ➤ In the case of a clear pressure drop clean the strainers ↪ Servicing, Page 29.

## 12 Servicing

### 12.1 Dangers during servicing



#### The following safety instructions must be observed strictly:

- Have all work carried out only by authorized qualified personnel.
- Before beginning work on the pump station ensure that the electrical power supply is deenergized and is secured against being switched back on.
- Before beginning work, let the pump station cool down slowly to the ambient temperature. Avoid rapid temperature changes.
- Pumped liquids can be hot, poisonous, combustible and caustic. Use corresponding protective equipment.
- Ensure that the pump station is depressurized and that shut-off devices are not operated uncontrolled.
- Collect any discharging pumped liquid safely and dispose of it in an environmentally compatible manner in accordance with the applicable local regulations.
- Ensure that the collection tank for discharging pumped liquids is sufficiently large.
- Observe the tightening torques ↪ Appendix, Page 38.
- Observe the operating instructions and data sheets of the components.

### 12.2 Wear

#### 12.2.1 Signs of wear

The following table lists signs of progressive wear of individual station elements:

Finding	Cause	Elimination
Increased running noises	Incipient damage to bearing	—➤ Replace the pump.
Increased leaking	Incipient damage to seal	—➤ Replace the shaft seal.
Deposits at the shaft seal	Low-volatile liquids	—➤ Clean the shaft seal.
Increased play in the coupling	Advanced wear of the coupling intermediate ring	—➤ Replace the coupling intermediate ring.

## 12 Servicing

### 12.3 Servicing the pump station

Finding	Cause	Elimination
Reduction in the delivery rate or pressure under constant operating conditions	Advanced wear of screws and housing	→ Replace the pump.
Increased pressure drop at the strainer	Soiling of the strainers	→ Clean the strainer.

Tab. 15: Signs of wear

#### 12.3 Servicing the pump station

Personnel qualification:	<input type="checkbox"/> Fitter
Personal protective equipment:	<input type="checkbox"/> Work clothing <input type="checkbox"/> Face protection <input type="checkbox"/> Protective gloves <input type="checkbox"/> Protective helmet
Aids:	<input type="checkbox"/> Collection tank



#### DANGER

##### Risk of death resulting from electric shock.

- ▶ Ensure that the electrical power supply is de-energized and is secured against being switched back on.
- ▶ Before commissioning ensure correct grounding and equipotential bonding.
- ▶ Observe the operating instructions of the electrical components.



#### WARNING

##### Risk of injury through emitted pumped liquid.

Pumped liquids can be hot, poisonous, combustible and caustic.

- ▶ Wear personal protective clothing during all the work. Ensure face protection.
- ▶ Collect any discharging pumped liquid safely and dispose of it in an environmentally compatible manner in accordance with the applicable local regulations.

→ Carry out all servicing work in accordance with the operating instructions of the pump and of the further components.

#### 12.4 Replacing the pump

Personnel qualification:	<input type="checkbox"/> Fitter <input type="checkbox"/> Electrician
Personal protective equipment:	<input type="checkbox"/> Work clothing <input type="checkbox"/> Face protection <input type="checkbox"/> Protective gloves
Aids:	<input type="checkbox"/> Collection tank



#### DANGER

##### Risk of death resulting from electric shock.

- ▶ Ensure that the electrical power supply is de-energized and is secured against being switched back on.
- ▶ Before commissioning ensure correct grounding and equipotential bonding.
- ▶ Observe the operating instructions of the electrical components.



### ⚠ WARNING

#### Risk of injury through emitted pumped liquid.

Pumped liquids can be hot, poisonous, combustible and caustic.

- ▶ Wear personal protective clothing during all the work. Ensure face protection.
- ▶ Collect any discharging pumped liquid safely and dispose of it in an environmentally compatible manner in accordance with the applicable local regulations.
- ▶ If work on the blocked part of the pump station takes longer, monitor the filling level of the strainer housing and catch the leakage.



### ⚠ WARNING

#### Risk of injury by discharging pumped liquid when replacing pump without preceding pressure relief.

- ▶ Open the vent screws at the pump flange by a maximum of 2 rotations in order to reduce the internal pressure in the housing.

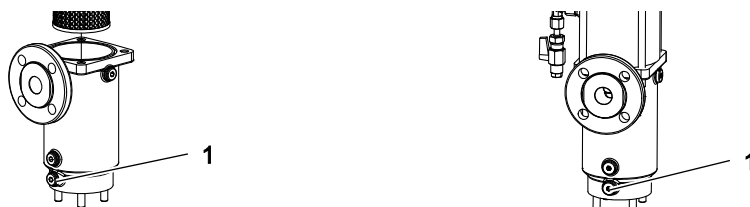

Fig. 18: Strainer (left) / Deaerator with integrated strainer (right)

1. ▶ Switch off the motor and secure it against being switched back on.
2. ▶ Close the pressure-side and suction-side shut-off devices.
3. ▶ Open the vent screws at the pump flange by a maximum of 2 rotations in order to reduce the internal pressure in the housing.
4. ▶ Drain the strainer by means of the drain screw 1.
5. ▶ Dismantle the pump.
6. ▶ Clean the sealing surfaces, place on new flat gaskets.
7. ▶ Place the new pump in position and mount it.
8. ▶ Open the pressure-side and suction-side shut-off devices, fill the station and vent, ↻ Commissioning, Page 23.

## 12.5 Cleaning the strainer

The frequency of cleaning the filter depends on the degree of soiling of the pumped liquid. In case of strongly soiled strainers cavitation and strong noise generation arise. The suction-side pressure gauge is used to indicate the degree of soiling.

Personnel qualification:	<input type="checkbox"/> Trained personnel
Personal protective equipment:	<input type="checkbox"/> Work clothing <input type="checkbox"/> Face protection <input type="checkbox"/> Protective gloves <input type="checkbox"/> Safety boots
Aids:	<input type="checkbox"/> Collection tank <input type="checkbox"/> Solvent

## 13 Disposal

### 13.1 Dismantling and disposing of the pump station



#### **WARNING**

##### **Risk of injury through emitted pumped liquid.**

Pumped liquids can be hot, poisonous, combustible and caustic.

- ▶ Wear personal protective clothing during all the work. Ensure face protection.
- ▶ Collect any discharging pumped liquid safely and dispose of it in an environmentally compatible manner in accordance with the applicable local regulations.
- ▶ If work on the blocked part of the pump station takes longer, monitor the filling level of the strainer housing and catch the leakage.



#### **WARNING**

##### **Risk of injury by emitted pumped liquid when opening the strainer without preceding pressure relief.**

- ▶ Open the vent screw/vent cock by a maximum of 2 rotations in order to reduce the pressure in the strainer.

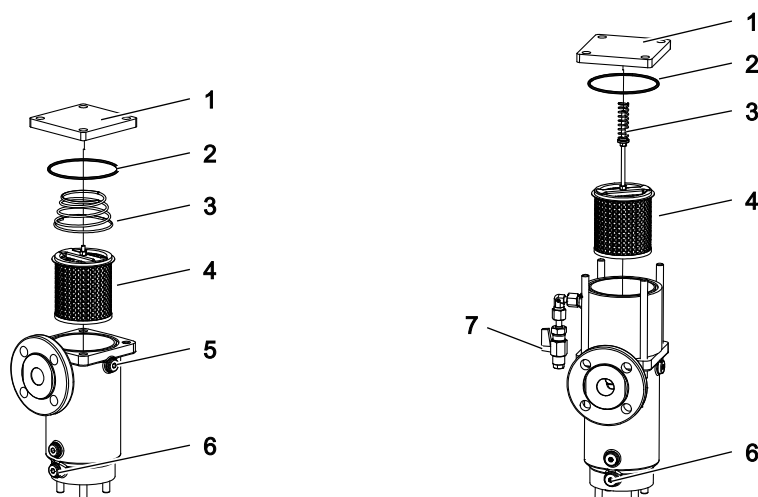

Fig. 19: Strainer (left) / Deaerator with integrated strainer (right)

1. ▶ Close the pressure-side and suction-side shut-off devices.
2. ▶ Open the vent screw **6**/vent cock **7** carefully in order to reduce the pressure in the strainer.
3. ▶ Drain the strainer by means of the drain screw **6**.
4. ▶ Remove the strainer cover **1**, remove the strainer insert **4** and clean.
5. ▶ Check all seals for damage and, if required, replace.
6. ▶ Put the strainer insert **4** back in and close the strainer cover **1**. In the process ensure that the O-ring **2** is positioned correctly.
7. ▶ Close the vent screw **6**/vent cock **7**.
8. ▶ Open the pressure-side and suction-side shut-off devices, fill the station and vent, ↴ Commissioning, Page 23.

## 13 Disposal

### 13.1 Dismantling and disposing of the pump station

Personnel qualification:	<input type="checkbox"/> Fitter
Personal protective equipment:	<input type="checkbox"/> Work clothing <input type="checkbox"/> Face protection <input type="checkbox"/> Protective gloves <input type="checkbox"/> Safety boots
Aids:	<input type="checkbox"/> Solvents or industrial cleaners suitable for the pumped liquid <input type="checkbox"/> Collection tank









### **WARNING**

#### **Danger of poisoning and environmental damage through residues.**

- ▶ Wear personal protective equipment during all the work. Ensure face protection.
- ▶ Before disposal collect any pumped or test liquid still present safely and dispose of it in an environmentally compatible manner in accordance with the applicable local regulations.
- ▶ Before disposing neutralize the residues.

#### Requirement:

- ✓ Disconnect the pump station from the power supply and secure it against being switched back on
  - ✓ Pump station cooled down to the ambient temperature and disconnected from the pipe system
  - ✓ Pump station drained completely
  - ✓ Pump station at a location suitable for dismantling
1.  Dismantle the pump station and disassemble it into its individual parts.
  2.  Clean residues of the pumped liquid from the individual parts.
  3.  Separate sealing elements made of elastomers and ceramics (SiC) from the pump station and dispose of them in separately.
  4.  Recycle iron parts.





## 14 Troubleshooting

### 14.1 Possible faults

Faults can have different causes. The following tables list the symptoms of a fault, the possible causes and measures for troubleshooting.

Identifica- tion	Fault
1	No pump suction
2	Delivery rate too low
3	Pump too loud
4	Motor overload
5	Uneven delivery rate
6	Pump has seized
7	Shaft seal leaks

### 14.2 Troubleshooting

Fault identification							Cause	Remedy
1	-	-	-	-	-	-	Pump suction line closed	 Check the shut-off devices. If required, open.
1	2	3	-	5	-	-	Parts soiled (filter, suction line, suction valve, strainer)	 Clean parts.
1	2	3	-	5	-	-	Suction head too high	 Reduce the level difference. -or- Reduce the line length. -or- Increase the line cross-section. -or- Heat up the pumped liquid. -or- Install a filter / strainer with a larger mesh width. Ensure that the permissible mesh width is not exceeded.
1	-	3	-	-	-	-	Level in the intake container too low	 Fill the intake container.

## 14 Troubleshooting

### 14.2 Troubleshooting

Fault identification							Cause	Remedy
1	-	-	-	-	-	-	Soiling of the filters/strainers	<ul style="list-style-type: none"> <li>→ Clean the filters/strainers ↪ Servicing, Page 29.</li> </ul>
1	-	-	-	-	-	-	Too little pumped liquid in the pump	<ul style="list-style-type: none"> <li>→ Fill the pump with pumped liquid.</li> </ul>
1	-	-	-	-	-	-	Incorrect pump direction of rotation	<ul style="list-style-type: none"> <li>→ Swop the two electrical connection phases ↪ Connection, Page 20.</li> </ul>
1	-	3	4	5	-	-	Viscosity of the pumped liquid too high	<ul style="list-style-type: none"> <li>→ Increase the temperature of the pumped liquid.</li> <li>-or-</li> <li>Decrease the speed.</li> </ul>
-	2	-	-	-	-	-	Viscosity of the pumped liquid too low	<ul style="list-style-type: none"> <li>→ Reduce the temperature of the pumped liquid.</li> <li>-or-</li> <li>Increase the speed.</li> </ul>
-	2	3	-	5	-	-	Airlock/gas in the pumped liquid	<ul style="list-style-type: none"> <li>1. → Test the pipe system for air admission, replace leaking parts.</li> <li>2. → Reduce the suction head.</li> <li>-or-</li> <li>Increase the inlet pressure.</li> </ul>
-	2	-	4	-	-	-	Speed/frequency/voltage of the motor false	<ul style="list-style-type: none"> <li>1. → Ensure that the motor frequency and voltage match the operating voltage.</li> <li>2. → Ensure that the speed of the motor matches the rating plate of the pump. If necessary adjust the speed.</li> </ul>
-	2	-	-	-	-	-	Advanced wear of the housing/screw set	<ul style="list-style-type: none"> <li>→ Contact the manufacturer.</li> </ul>
-	-	-	-	-	-	7	Advanced wear of sealing surfaces	<ul style="list-style-type: none"> <li>→ Replace the seal and check the pumped liquid for abrasive substances. If required, replace the filter/strainer.</li> <li>-or-</li> <li>Contact the manufacturer.</li> </ul>
-	-	3	-	-	-	-	Coupling aligned incorrectly	<ul style="list-style-type: none"> <li>→ Assemble the coupling and motor correctly, see the associated operating instructions of the pumps.</li> </ul>
-	-	3	-	-	-	-	Pump subject to mechanical stress	<ul style="list-style-type: none"> <li>1. → Support the weight of the pipe system.</li> <li>2. → Connect the pump station correctly to the pipe system ↪ Connection, Page 20.</li> </ul>
-	-	3	-	-	-	-	Vibrations/pulsations in the system	<ul style="list-style-type: none"> <li>→ Bear the pump station elastically.</li> <li>-or-</li> <li>Make the connections with hoses.</li> </ul>
-	-	3	-	-	-	-	Flow speed in the pressure line or suction line too high	<ul style="list-style-type: none"> <li>→ Set the flow speed in the pressure line so that it does not exceed 3 m/s.</li> <li>-or-</li> <li>Set the flow speed in the suction line so that it does not exceed 1 m/s.</li> <li>-or-</li> <li>Contact the manufacturer.</li> </ul>
-	-	3	4	-	-	7	Ball bearing damaged	<ul style="list-style-type: none"> <li>→ Replace the ball bearing, see corresponding operating instructions of the pump.</li> </ul>
-	2	3	4	-	-	7	Superficial damage to pump parts coming into contact with the liquid	<ul style="list-style-type: none"> <li>→ Contact the manufacturer.</li> </ul>
-	-	-	-	-	-	7	Shaft seal damaged through dry running	<ul style="list-style-type: none"> <li>→ Replace the shaft seal, see corresponding operating instructions of the pump.</li> </ul>

Fault identification							Cause	Remedy
-	-	-	-	-	-	7	Inlet pressure too high	<ol style="list-style-type: none"> <li>1. ➤ Reduce the inlet pressure at the system side.</li> <li>2. ➤ Replace the shaft seal, see corresponding operating instructions of the pump.</li> </ol>
-	-	-	-	-	-	7	Inlet pressure too low	<ul style="list-style-type: none"> <li>➤ Install a non-return valve at the pressure side.</li> </ul>
-	-	-	-	-	-	7	Shaft seal is overloaded through thermal/chemical influences	<ol style="list-style-type: none"> <li>1. ➤ Check the maximum operating temperature.</li> <li>2. ➤ Check the suitability and resistance of the elastomers with regard to the pumped liquid.</li> </ol> <p>-or-</p> <p>Contact the manufacturer.</p>
-	-	-	-	-	-	7	Overload of the shaft seal by pressure build-up during the heating process	<ul style="list-style-type: none"> <li>➤ Open the pressure-side/suction-side shut-off device in order to avoid a pressure build-up through heat expansion of the pumped liquid.</li> </ul>
1	2	3	4	5	-	-	Cold start when delivering high-viscosity liquids	<ul style="list-style-type: none"> <li>➤ Install the heating system.</li> </ul>
-	-	3	-	-	6	-	Differential pressure is too high and has overloaded the idle screws	<ul style="list-style-type: none"> <li>➤ Contact the manufacturer.</li> </ul>
-	-	3	-	-	6	-	Viscosity is too low and has overloaded the idle screws	<ul style="list-style-type: none"> <li>➤ Contact the manufacturer.</li> </ul>
1	2	3	4	-	-	7	Pump damaged through dry running	<ul style="list-style-type: none"> <li>➤ Contact the manufacturer.</li> </ul>
1	-	-	-	-	-	-	Pump does not vent	<ul style="list-style-type: none"> <li>➤ Vent the pressure line at the highest point.</li> </ul>
-	2	-	-	5	-	-	Pressure maintaining valve set incorrectly	<ul style="list-style-type: none"> <li>➤ Set the pressure maintaining valve ↪ During operation, Page 26.</li> </ul>

Tab. 16: Fault table

15 Spare parts

15.1 Overview

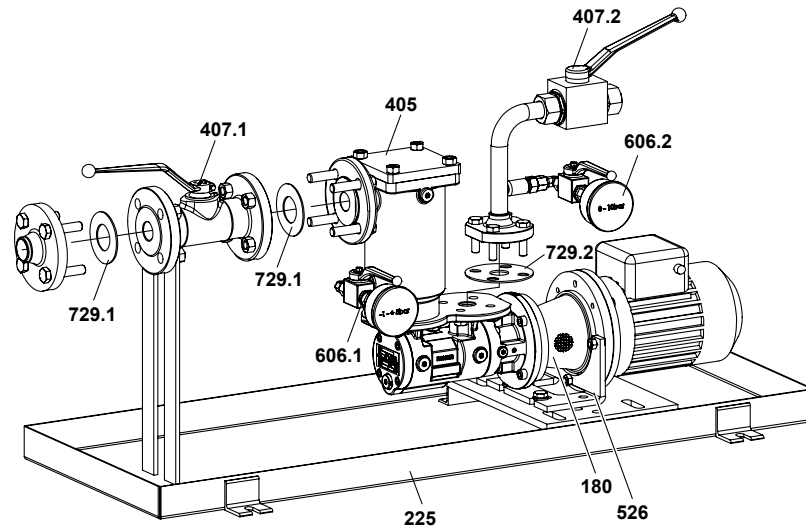

Fig. 20: EKL/EKS 11

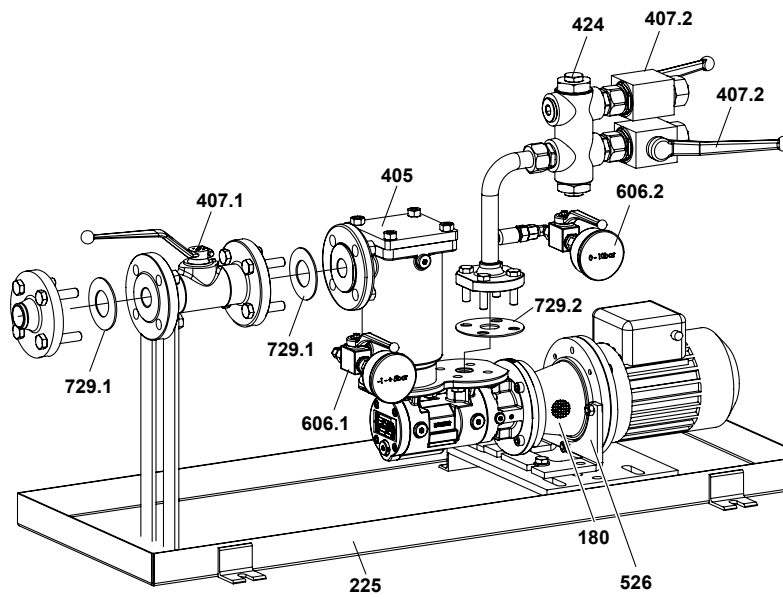

Fig. 21: EKL/EKS 12

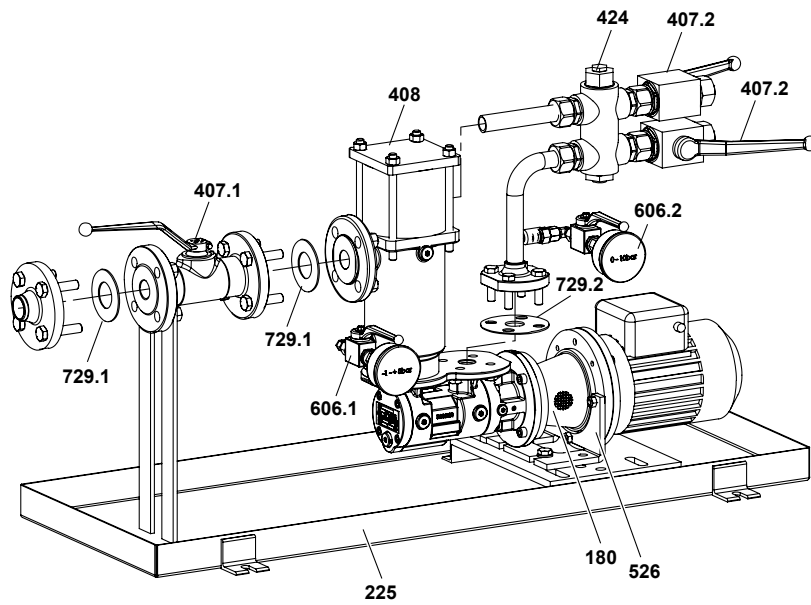

Fig. 22: EKL/EKS 13

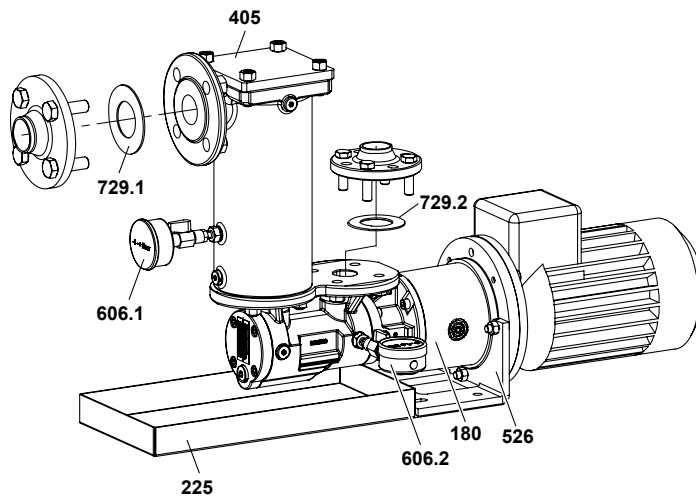

Fig. 23: EKS 11 special design

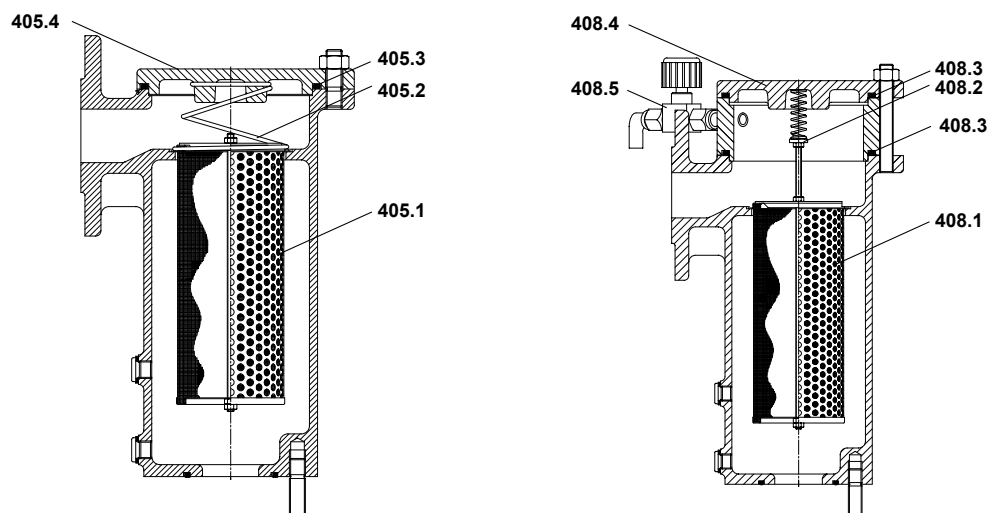

Fig. 24: Strainer (left) / Deaerator with integrated strainer (right)

## 16 Appendix

### 16.1 Tightening torques for screws with metric screw threads with and without wedge lock washers

Item No.	Part	Item No.	Part
180	Pump bracket	408.2	Conical spring
225	Base frame with oil pan	408.3	O-ring
405	Strainer	408.4	Strainer cover
405.1	Strainer insert	408.5	Vent cock
405.2	Conical spring	424	Pressure maintaining valve
405.3	O-ring	526	Pump bracket foot
405.4	Strainer cover	606.1	Suction-side pressure gauge
407.1	Suction-side ball valve	606.2	Pressure-side pressure gauge
407.2	Pressure-side ball valve	729.1	Flat gasket
408	Deaerator with integrated strainer	729.2	Flat gasket
408.1	Strainer insert		

Tab. 17: List of parts

## 16 Appendix

### 16.1 Tightening torques for screws with metric screw threads with and without wedge lock washers

**Note** In the case of galvanised screw plugs and screw plugs made of stainless steel the inner thread and outer thread have to be greased thorough before mounting in order to prevent threads from seizing.

**Note** The manufacturer recommends tightening screws with wedge lock washers according to the table three times after another with the same tightening torque

Tightening torque [Nm]							
Screws with head contact surface					Countersunk screws		
Thread	5.6	8.8	10.9	8.8+ Alu*	Stainless steel screws A2 and A4		8.8
					Property class 70	Property class 80	
M 3	0.6	1.5	–	1.2	1.1	1.3	1.0
M 4	1.4	3.0	4.1	2.3	2.0	2.3	2.0
M 5	2.7	6.0	8.0	4.8	3.9	4.7	5.0
M 6	4.7	10.3	14.0	7.6	6.9	8.0	9.0
M 8	11.3	25.0	34.0	18.4	17.0	22.0	14.0
M 10	23.0	47.0	68.0	36.8	33.0	43.0	36.0
M 12	39.0	84.0	117	64.0	56.0	75.0	60.0
M 14	62.0	133	186	101	89.0	–	90.0
M 16	96.0	204	285	155	136	180	100
M 18	133	284	390	224	191	–	–
M 20	187	399	558	313	267	370	135
M 24	322	687	960	540	460	605	360

Tab. 18: Tightening torques metric screw thread

\*When screwing into aluminium, the tightening torque reduces by 20 % when the screw-in depth is less than double the thread diameter.

## 16.2 Tightening torques for screw plugs with thread measured in inches and elastomer seal

**16.2 Tightening torques for screw plugs with thread measured in inches and elastomer seal**

**Note** In the case of galvanised screw plugs and screw plugs made of stainless steel the inner thread and outer thread have to be greased thorough before mounting in order to prevent threads from seizing.

Tightening torque [Nm]	
Thread	Galvanized + stainless steel
G 1/8"	13.0
G 1/4"	30.0
G 3/8"	60.0
G 1/2"	80.0
G 3/4"	120
G 1"	200
G 1 1/4"	400
G 1 1/2"	450

Tab. 19: Tightening torques with thread measured in inches

**16.3 Contents of the Declaration of Conformity**

The products described in these instructions are machinery in the sense of the Directive 2006/42/EC. The original of the EC Declaration of Conformity is enclosed with the machinery at delivery.

The machinery fulfils all the relevant provisions of the following directives:

Number	Name	Remark
2006/42/EC	Machinery Directive	–
2014/68/EU	Pressure Equipment Directive	–
2014/30/EU	Directive on Electromagnetic Compatibility	Only for machinery with electrical components
2014/35/EU	Low Voltage Directive	Only for machinery with electrical components
2014/34/EU	Directive on Use in Potentially Explosive Areas (ATEX)	Only for machinery in ATEX version

Tab. 20: Directives observed



# KRAL

