

SECTION A-A
(1 : 2)

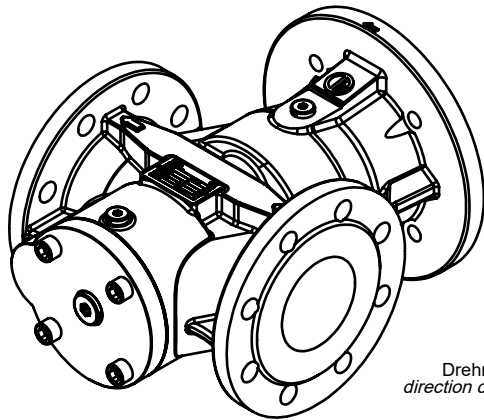

Drehrichtung: rechts
direction of rotation: clockwise

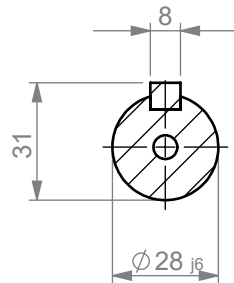

**Anschlüsse für
Entleerung/Entlüftung G 1/4"**
MS... Saugseite
MD... Druckseite

connections for
drain/ventilation plug G 1/4"
MS... suction side
MD... pressure side

Maße ohne Toleranzangaben nach:
Untoleranced dimensions:

ISO 2768 - c
Baugruppe
Assembly

EN ISO 13920 - B
Schweißteil
Welded part

Schraubenspindelpumpe / Pumpenstation
Screw-pump / Pump-station

RFI 160 - 210
RFI 160 - 210

Datum: / Date:
09.03.2020

Erstellt: / Drawn:
J. Golemac

Datum: / Date:
09.03.2020

Geprüft: / Reviewed:
P. Sulzer

Maßstab: / Scale:
1:4

Gewicht: / Weight:
35

KRAL

KRAL GmbH
Bildgasse 40, Industrie Nord
6890 Lustenau, Austria
www.kral.at

Schutzvermerk ISO 16016 beachten!
Refer to protection notice ISO 16016!

Alle Dimensionen in:
All dimensions in:



A4 Blatt: / Sheet: 1 von: / of: 1

TMP