

DN25/PN16
EN1092-2
raised face

DN25/PN16
EN1092-2
raised face

MS

MD

leakage vent
hole - $\phi 20$

SECTION A-A
(1 : 1)

leakage vent
hole - $\phi 20$

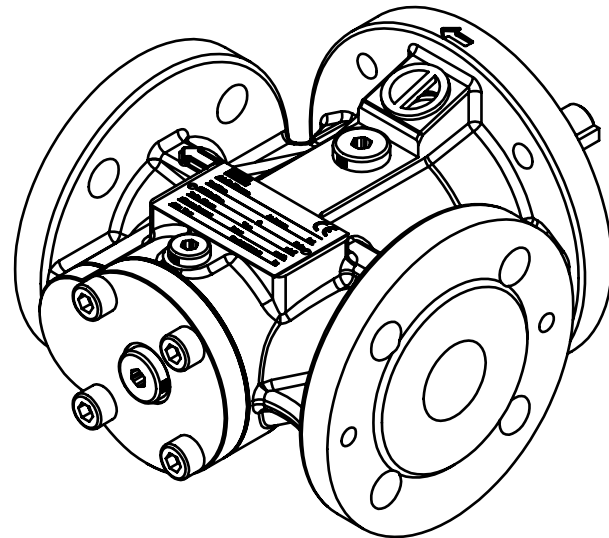

**Anschlüsse für
Entleerung/Entlüftung**
MS... Saugseite G 1/8"
MD... Druckseite G 1/4"

connections for
drain/ventilation plug
MS... suction side G 1/8"
MD... pressure side G 1/4"

Drehrichtung: rechts
direction of rotation: clockwise



vom Antrieb aus gesehen
viewed from the drive

Maße ohne Toleranzangaben nach:
Untoleranced dimensions:

ISO 2768 - c
Baugruppe
Assembly

EN ISO 13920 - B
Schweißteil
Welded part

Schraubenspindel-pumpe / Pumpenstation
Screw-pump / Pump-station

RFI 15 - 20

RFI 15 - 20

Datum: / Date:
09.03.2020

Datum: / Date:
09.03.2020

Maßstab: / Scale:
1:2

Erstellt: / Drawn:
J. Golemac

Geprüft: / Reviewed:
P. Sulzer

Gewicht: / Weight:
8 [kg]

KRAL

KRAL GmbH
Bildgasse 40, Industrie Nord
6890 Lustenau, Austria
www.kral.at

Schutzvermerk ISO 16016 beachten!
Refer to protection notice ISO 16016!

Alle Dimensionen in:
All dimensions in:

[mm]
[mm]



A4 Blatt: / Sheet: 1 von: / of: 1

TMP