

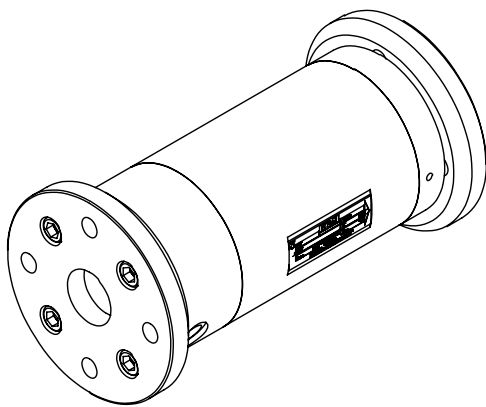

Operating instructions

KRAL

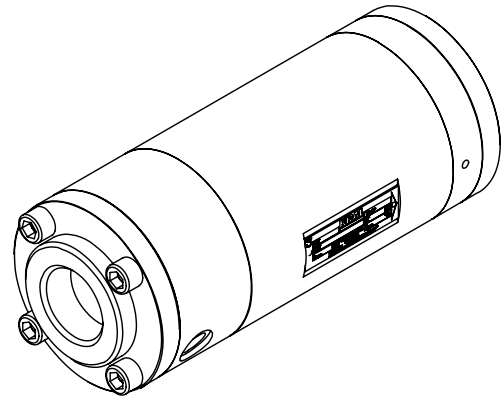

KRAL flowmeters.

Series OMG

OIO 14en-GB
Edition 2020-01
Original instructions

1 About this document	4	8.1 Dangers during installation	24
1.1 General information	4	8.2 Dangers during removal	24
1.2 Target groups	4	8.3 Installing the flowmeter	24
1.3 Symbols	4	8.3.1 Protecting the flowmeter against soiling	24
1.3.1 Danger levels	4	8.3.2 Installation types	24
1.3.2 Danger signs	4	8.3.3 Installation recommendation	25
1.3.3 Symbols in this document	5	8.3.4 Installing the flowmeter	26
1.4 Associated documents	5	8.4 Removing the flowmeter	27
2 Safety	5	9 Connection	27
2.1 Proper use	5	9.1 Dangers during connection work	27
2.2 Foreseeable misuse	5	9.2 Connecting the flowmeter to the pipe system	28
2.3 Obligations of the operator-owner	6	9.3 Connecting the pick up	28
2.4 Safety instructions	6	10 Operation	29
2.4.1 Fundamental safety instructions	6	10.1 Dangers during operation	29
3 Identification	6	10.2 Commissioning	29
3.1 Type code	6	10.2.1 Cleaning the pipe system	29
3.2 Rating plate	8	10.2.2 Checking the function	29
4 Technical data	8	10.2.3 Commissioning the flowmeter	30
4.1 Operating limits	8	10.3 Decommissioning	30
4.2 Pressure pulsation	8	10.3.1 Switching off the flowmeter	30
4.3 Maximum values	8	10.4 Recommissioning	30
4.4 Substitute operating data	10	10.4.1 Recommissioning the flowmeter	30
4.5 Sound pressure level	10	11 Maintenance	31
4.6 Dimensions and weights	10	11.1 Required maintenance	31
4.6.1 Pipe thread (BSPP thread)	10	11.2 Maintaining flowmeters	31
4.6.2 DIN flange	11	11.3 Recalibration of the flowmeter	31
4.7 Pressure bearing capacity	12	12 Servicing	32
4.7.1 Pressure bearing capacity OMG-013	12	12.1 Dangers during servicing	32
4.7.2 Pressure bearing capacity OMG-020	13	12.2 Replacing seals and ball bearings	32
4.7.3 Pressure bearing capacity OMG-032	14	12.2.1 Removing seals and ball bearings OMG-013	32
4.7.4 Pressure bearing capacity OMG-052	15	12.2.2 Installing seals and ball bearings OMG-013	32
4.7.5 Pressure bearing capacity OMG-068	16	12.2.3 Removing seals and ball bearings OMG-020/ OMG-032	33
4.7.6 Pressure bearing capacity OMG-100	17	12.2.4 Installing seals and ball bearings OMG-020/ OMG-032	34
4.7.7 Pressure bearing capacity OMG-140	18	12.2.5 Removing seals and ball bearings OMG-052/ OMG-068	36
5 Function description	19	12.2.6 Installing seals and ball bearings OMG-052/ OMG-068	37
5.1 Structure	19	12.2.7 Removing seals and ball bearings OMG-100/ OMG-140	38
5.2 Functional principle	19	12.2.8 Installing seals and ball bearings OMG-100/ OMG-140	39
5.3 Rolling bearings	19	13 Disposal	41
5.4 Signal generation	20	13.1 Dangers during disposal	41
5.5 Linearization	20	13.2 Dismantling and disposing of the flowmeter	41
5.6 Temperature compensation	20	14 Troubleshooting	42
5.7 Recognition of flow direction	20	14.1 Possible faults	42
6 Transportation, storage	21	14.2 Troubleshooting	42
6.1 Dangers during transportation	21	15 Spare parts	44
6.2 Dangers during storage	21	15.1 Overview OMG-013	44
6.3 Unpacking and checking the state of delivery	21	15.2 Overview OMG-020/OMG-032	45
6.4 Transporting flowmeters	21	15.3 Overview OMG-052/OMG-068	46
6.5 Storing the flowmeter	22	15.4 Overview OMG-100/OMG-140	48
7 Preservation	22		
7.1 Preservation table	22		
7.2 Preserving the inner surfaces	22		
7.3 Preserving the outer surfaces	23		
7.4 Removing the preservation	23		
8 Installation, removal	24		

16 Accessories	49
16.1 Heating	49
16.1.1 Possible types of heating	49
16.1.2 Technical data of the electrical heating system	49
16.1.3 Technical data of the fluid heating system	49
16.1.4 Installing the heating system	49
16.2 Junction box	51
16.2.1 Function description	51
16.2.2 Technical data	51
16.2.3 Installing the junction box	51
16.3 Extension cable	52
16.3.1 Function description	52
16.3.2 Technical data	52
16.3.3 Connecting the extension cable	52
17 Appendix	54
17.1 Tightening torques for screws with metric screw threads with and without wedge lock washers	54
17.2 Tightening torques for screw plugs with thread measured in inches and elastomer seal	54
17.3 Tightening torques and widths for threaded rings	54
17.4 Contents of the Declaration of Conformity	55

1 About this document

1.1 General information

1 About this document

1.1 General information

These instructions form part of the product and must be kept for future reference. Furthermore please observe the associated documents.

1.2 Target groups

The instructions are intended for the following persons:

- Persons who work with the product
- Operator-owners who are responsible for the use of the product

Persons who work with the product must be qualified. The qualification ensures that possible dangers and damage to property that are connected to the activity are detected and avoided. These persons are qualified personnel who carry out the work properly due to their training, knowledge and experience and on the basis of the relevant provisions.

Information on the required qualification of the personnel is provided separately at the beginning of the individual chapters in these instructions. The following table provides an overview.

Target group	Activity	Qualification
Transport personnel	Transporting, unloading, setting up	Qualified personnel for transport, mobile crane operators, crane operators, forklift operators
Fitter	Mounting, connection	Qualified personnel for mounting
Electrician	Electrical connection	Qualified personnel for electric installation
Trained personnel	Delegated task	Personnel trained by the operator-owner who know the task delegated to them and the possible dangers arising through improper behaviour.



Tab. 1: Target groups



1.3 Symbols

1.3.1 Danger levels









	Signal word	Danger level	Consequences of non-observance
	DANGER	Immediate threat of danger	Serious personal injury, death
	WARNING	Possible threat of danger	Serious personal injury, invalidity
	CAUTION	Potentially dangerous situation	Slight personal injury
	ATTENTION	Potentially dangerous situation	Material damage

1.3.2 Danger signs

	Meaning	Source and possible consequences of non-observance
	Electrical voltage	Electrical voltage causes serious physical injury or death.
	Raised load	Falling objects can result in serious physical injury or death.
	Heavy load	Heavy loads can result in serious back problems.

	Meaning	Source and possible consequences of non-observance
	Risk of slipping	Discharging pumped liquid and oils on the foundation or tread surfaces can cause falls with serious physical injury or death.
	Flammable substances	Discharging pumped liquid and oils can be easily inflammable and can result in serious burns.
	Hot surface	Hot surfaces can cause burns.

1.3.3 Symbols in this document

	Meaning
	Warning personal injury
	Safety instruction
	Request for action
1. 	Multi-step instructions for actions
2. 	
3. 	
	Action result
	Cross-reference

1.4 Associated documents

- Calibration certificate
- Declaration of conformity according to EU Directive 2006/42/EC
- Manufacturer's declaration according to EU Directive 2014/68/EU
- Corresponding operating instructions for accessories

2 Safety

2.1 Proper use

- Flowmeter solely for flow measurement of lubricating liquids that are chemically neutral and that do not contain gas or solid components.
- Flowmeters require the operation with clean liquids. If coarse soiling, solid particles in the liquid or abrasive fine particles occur during operation, the flowmeter has to be protected additionally by a correspondingly dimensioned operating filter in the pipe system.
- Use the flowmeter only within the operating limits specified on the rating plate and in the chapter "Technical data". Deviating operating data can result in damage to the flowmeter. In the case of operating data that do not agree with the specifications on the rating plate, please contact the manufacturer.
- Strong changes in the flow rate (for example rapid shutdown, pulsations, etc.) cause marked pressure differences in the flowmeter and can damage the measuring unit. The pressure loss of the flowmeter must not exceed the values shown in the chapter "Technical data"

2.2 Foreseeable misuse

- Any use that extends beyond the proper use or any other use is misuse.
- The product is not suitable for pumping liquids outside the operational limits.
- Any bypassing or deactivation of safety equipment during operation is prohibited.

3 Identification

2.3 Obligations of the operator-owner

2.3 Obligations of the operator-owner

The operator-owner is the person who operates the product commercially or permits a third party to use it and who bears the legal responsibility for the product, the protection of the personnel and third parties during its operation.

The product is used in industrial applications. The operator-owner is therefore subject to the statutory obligations concerning occupational health and safety.

In addition to the safety instructions in these instructions, the regulations on safety, accident prevention and environmental protection respectively valid for the range of application of the product are to be observed.

2.4 Safety instructions

2.4.1 Fundamental safety instructions



The following safety instructions must be observed strictly:

- Read these operating instructions carefully and observe them.
- Read the operating instructions for the electronic unit and the sensors carefully and observe them.
- Have work only carried out by qualified personnel / trained personnel.
- Wear personal protective equipment and work carefully.
- Pumped liquids can be subject to high pressure and can result in personal injury and damage to property in case of incorrect operation or damaged components.
- Pumped liquids can be hot, poisonous, combustible and caustic.
- Observe the associated data sheets and safety regulations when handling dangerous materials.
- Avoid skin contact with system parts carrying liquids at operating temperatures exceeding 60 °C.
- Collect any discharging pumped liquid safely and dispose of it in an environmentally compatible manner in accordance with the applicable local regulations. Neutralize residues.
- Keep the mounting surfaces, scaffolding, ladders, lifting platforms and tools clean in order to prevent slipping or stumbling.
- If pressurized or energized components are damaged, shut down the flowmeter immediately. Replace the components or flowmeter.

3 Identification

3.1 Type code

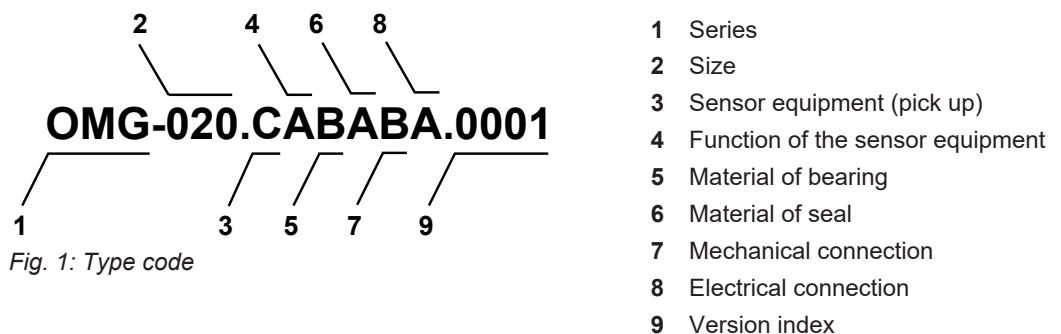

Item	Designation	Description	
1	Series	OME	Economy
		OMG	General/Universal
		OMH	High Pressure
		OMP	Performance
		OMS	Stainless steel
2	Size	Corresponds to the diameter of the measuring screw large in [mm]	
3	Sensor equipment (pick up)	A	BEG 06
		B	BEG 43
		C	BEG 44
		D	BEG 45
		E	BEG 45 + BEV 13
		F	BEG 47
		G	BEG 53
		H	BEG 54
		I	BEG 56
		J	BEG 60-62
X	Special design		
4	Function of the sensor equipment	A	Without recognition of flow direction
		B	With recognition of flow direction
		C	Without recognition of flow direction, with temperature compensation
		D	With recognition of flow direction, with temperature compensation
		X	Special design
5	Material of bearing	A	Steel
		B	Hybrid
		C	Stainless steel
		D	All-ceramic
		X	Special design
6	Material of seal	A	FPM (FKM)
		B	FFPM (FFKM)
		C	Low-temperature FPM
		D	EPDM
		X	Special design
7	Mechanical connection	A	Thread connection BSPP
		B	Flange connection DIN
		C	Thread connection NPT
		D	Flange connection ANSI
		E	Flange connection JIS
		F	Flange connection SAE
		X	Special design
8	Electrical connection	A	Loose cable end
		B	Cable gland junction box
		C	Cable gland compact sensor
		D	Fixing kit for display and processing unit
		E	Smart Solution version
		X	Special design
9	Version index	For internal administration	

Tab. 2: Type code

4 Technical data

3.2 Rating plate

3.2 Rating plate

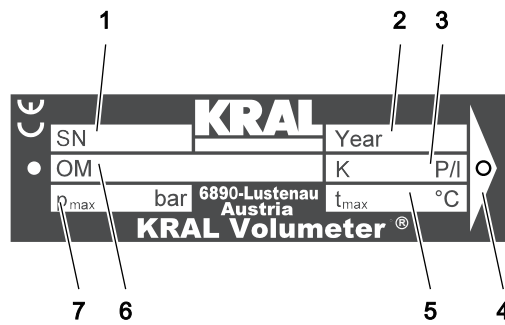

- 1 Serial number
- 2 Construction year
- 3 K-factor
- 4 Preferred flow direction
- 5 Max. temperature
- 6 Series
- 7 Max. pressure

Fig. 2: Rating plate

4 Technical data

4.1 Operating limits

The values specified on the rating plate and the calibration certificate apply. The permissible operating limits of individual values influence each other so that every application is checked individually by the manufacturer when selecting the flowmeter.

If no operating data are provided by the orderer, standardized substitute operating data are used.

4.2 Pressure pulsation

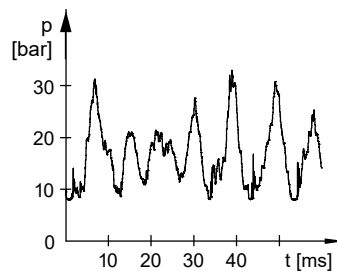

Fig. 3: Pressure pulses

Strong pressure pulsations in the system can reduce the service life of the flowmeter.

4.3 Maximum values

The following table shows the respective maximum values that, however, may not occur simultaneously. In addition, the operating limits of the corresponding completion, of the sealing material and of the pick up are to be observed.

	Unit	013	020	032	052	068	100	140
Maximum values								
Flow rate								
<input type="checkbox"/> Q_{max}	[l/min]	15	45	150	525	1050	3000	7500
<input type="checkbox"/> Q_{rated}	[l/min]	10	30	100	350	700	2000	5000
<input type="checkbox"/> Q_{min}	[l/min]	0.1	0.3	1.0	3.5	7.0	20.0	50.0
Max. pressure	[bar]	250			160	100	40	
Min. - max. temperature	[°C]	-20 ... +200						
Min. - max. viscosity	[mm ² /s]	1 – 1000000						
Measuring chamber volume	[ml/U]	1.6	6.3	25.6	112.7	251.3	833.3	2259.9
Rotation speed								
<input type="checkbox"/> $n(Q_{max})$	[min ⁻¹]	9120	7200	5850	4658	4182	3600	3318
<input type="checkbox"/> $n(Q_{rated})$	[min ⁻¹]	6090	4800	3900	3105	2784	2400	2214
<input type="checkbox"/> $n(Q_{min})$	[min ⁻¹]	61	48	39	31	28	24	22

Unit	013	020	032	052	068	100	140	
Additional maximum values when BEG 43D is used								
K1								
Pole number		2	4	6	8	10	14	20
K-factor	[P/l]	1216.0	640.0	234.0	71.0	39.8	16.8	8.9
Millilitre/pulse	[ml/P]	0.82	1.56	4.27	14.08	25.13	59.52	112.99
Pulse frequency								
<input type="checkbox"/> f1 (Q _{max})	[Hz]	304	480	585	621	697	840	1106
<input type="checkbox"/> f1 (Q _{rated})	[Hz]	203	320	390	414	464	560	738
<input type="checkbox"/> f1 (Q _{min})	[Hz]	2.0	3.2	3.9	4.1	4.6	5.6	7.4
Additional maximum values when BEG 44 is used								
K2								
Pole number		4	8	12	16	20	28	40
K-factor	[P/l]	2432.0	1280.0	468.0	142.0	79.6	33.6	17.7
Millilitre/pulse	[ml/P]	0.41	0.78	2.14	7.04	12.56	29.76	56.50
Pulse frequency								
<input type="checkbox"/> f2 (Q _{max})	[Hz]	608	960	1170	1243	1393	1680	2213
<input type="checkbox"/> f2 (Q _{rated})	[Hz]	405	640	780	828	929	1120	1475
<input type="checkbox"/> f2 (Q _{min})	[Hz]	4.1	6.4	7.8	8.3	9.3	11.2	14.8
Additional maximum values when BEG 45 is used								
K3								
Pole number		12	16	26	34	42	48	50
K-factor	[P/l]	7296.0	2560.0	1014.0	302.0	167.0	57.6	22.1
Millilitre/pulse	[ml/P]	0.14	0.39	0.99	3.31	5.98	17.40	45.20
Pulse frequency								
<input type="checkbox"/> f3 (Q _{max})	[Hz]	1824	1920	2535	2640	2927	2880	2763
<input type="checkbox"/> f3 (Q _{rated})	[Hz]	1216	1280	1690	1760	1949	1920	1842
<input type="checkbox"/> f3 (Q _{min})	[Hz]	12.2	12.8	16.9	17.6	19.5	19.2	18.4
		Observe flow range: If the value drops below Q _{min} , refer to the operating instructions of the associated pick up						
Additional maximum values when BEG 47D is used								
K1								
Pole number		2	4	6	8	10	14	20
K-factor	[P/l]	1216.0	640.0	234.0	71.0	39.8	16.8	8.9
Millilitre/pulse	[ml/P]	0.82	1.56	4.27	14.08	25.13	59.52	112.99
Pulse frequency								
<input type="checkbox"/> f1 (Q _{max})	[Hz]	304	480	585	621	697	840	1106
<input type="checkbox"/> f1 (Q _{rated})	[Hz]	203	320	390	414	464	560	738
<input type="checkbox"/> f1 (Q _{min})	[Hz]	2.0	3.2	3.9	4.1	4.6	5.6	7.4

4 Technical data

4.4 Substitute operating data

	Unit	013	020	032	052	068	100	140
Additional maximum values when BEG 53A/BEG 54A is used								
K4								
Pole number		12	16	26	34	42	73	102
K-factor	[P/l]	7296.0	2560.0	1014.0	302.0	167.0	87.6	45.1
Millilitre/pulse	[ml/P]	0.14	0.39	0.99	3.31	5.99	11.42	22.17
Pulse frequency								
<input type="checkbox"/> f4 (Q _{max})	[Hz]	1824	1920	2535	2643	2923	4380	5638
<input type="checkbox"/> f4 (Q _{rated})	[Hz]	1216	1280	1690	1762	1948	2920	3758
<input type="checkbox"/> f4 (Q _{min})	[Hz]	12.2	12.8	16.9	17.6	19.5	29.2	37.6

4.4 Substitute operating data

The following table shows standardized values for the flow rate, temperature and viscosity. These values can be used at the same time as maximum values without impairing the service life of the flowmeter. In addition, the operating limits of the corresponding completion, of the sealing material of the pick up and of the temperature sensor are to be observed.

	Unit	013	020	032	052	068	100	140
Flow rate								
<input type="checkbox"/> Q _{max}	[l/min]	10	30	100	350	700	2000	5000
<input type="checkbox"/> Q _{rated}	[l/min]	10	30	100	350	700	2000	5000
<input type="checkbox"/> Q _{min}	[l/min]	0.2	0.6	2.0	7.0	14.0	40.0	100.0
Max. pressure	[bar]	250			160	100	40	
Min. – max. temperature	[°C]	-20 ... +120						
Min. – max. viscosity	[mm ² /s]	1 – 200						

Tab. 3: Substitute operating data

4.5 Sound pressure level

The sound pressure level of the flowmeters amounts to less than 70 dB(A).

4.6 Dimensions and weights

4.6.1 Pipe thread (BSPP thread)

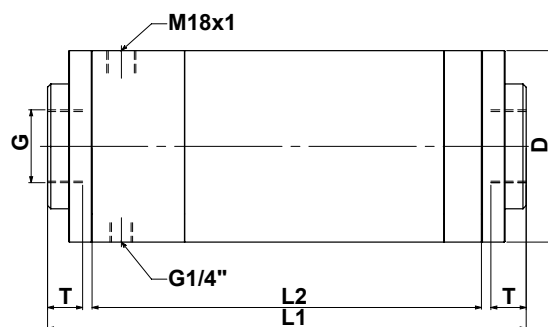

- G** Pipe thread
- M18x1** Pick up hole
- G1/4"** Temperature sensor hole
- D** Outer diameter
- L1** Total length
- L2** Length of the flowmeter without connections
- T** Max. screw-in depth

Fig. 4: Dimensional drawing pipe thread connection

	Unit	013	020	032	052	068	100	140
G	[inch]	1/2	3/4	1	1 1/2	2	4	6
Pressure stage	[bar]	250	250	250	160	100	40	40
D	[mm]	90	74	104	118	138	188	267
L1	[mm]	145	145	215	295	355	480	645
L2	[mm]	94	145	215	240	295	400	537
T	[mm]	16	16	18	27.5	30	40	54
Weight	[kg]	4.6	4.1	11	18	29	70	180

Tab. 4: Dimensions and weights - pipe thread connection

4.6.2 DIN flange

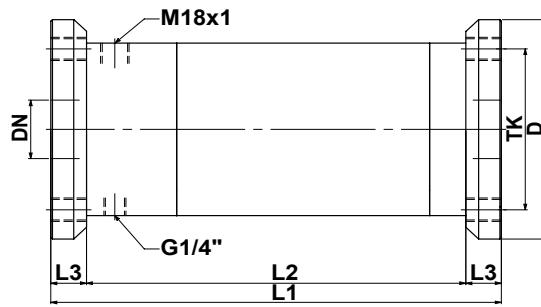

- DN** Nominal diameter flange
- M18x1** Pick up hole
- G1/4"** Temperature sensor hole
- D** Outer diameter
- L1** Total length
- L2** Length of the flowmeter without connections
- L3** Flange thickness
- TK** Pitch circle

Fig. 5: Dimensional drawing DIN flange connection

	Unit	013			020			032		
DN		15	15	15	20	15	15	32	25	25
Pressure stage	[bar]	40	160	250	40	160	250	40	160	250
D	[mm]	95	105	130	105	105	130	140	140	150
L1	[mm]	145	145	145	185	185	195	265	265	275
L2	[mm]	94	94	94	145	145	145	215	215	215
L3	[mm]	25.5*	25.5*	25.5	20	20	25	25	25	30
TK	[mm]	65	75	90	75	75	90	100	100	105
Weight	[kg]	4.7	4.8	6.0	6.0	6.0	8.1	16	16	19

Tab. 5: Dimensions and weights – DIN flange connection

*Screw-in depth is not equal to L3 but is 17 mm

	Unit	052		068		100		140	
DN		40	40	50	50	100	100	150	150
Pressure stage	[bar]	40	160	40	100	16	40	16	40
D	[mm]	150	170	165	195	220	235	285	300
L1	[mm]	285	295	340	355	450	460	600	610
L2	[mm]	240	240	295	295	400	400	537	537
L3	[mm]	22.5	27.5	22.5	30	25	30	31.5	36.5
TK	[mm]	110	125	125	145	180	190	240	250
Weight	[kg]	21	23	31	37	65	70	170	180

Tab. 6: Dimensions and weights – DIN flange connection

4 Technical data

4.7 Pressure bearing capacity

4.7 Pressure bearing capacity

4.7.1 Pressure bearing capacity OMG-013

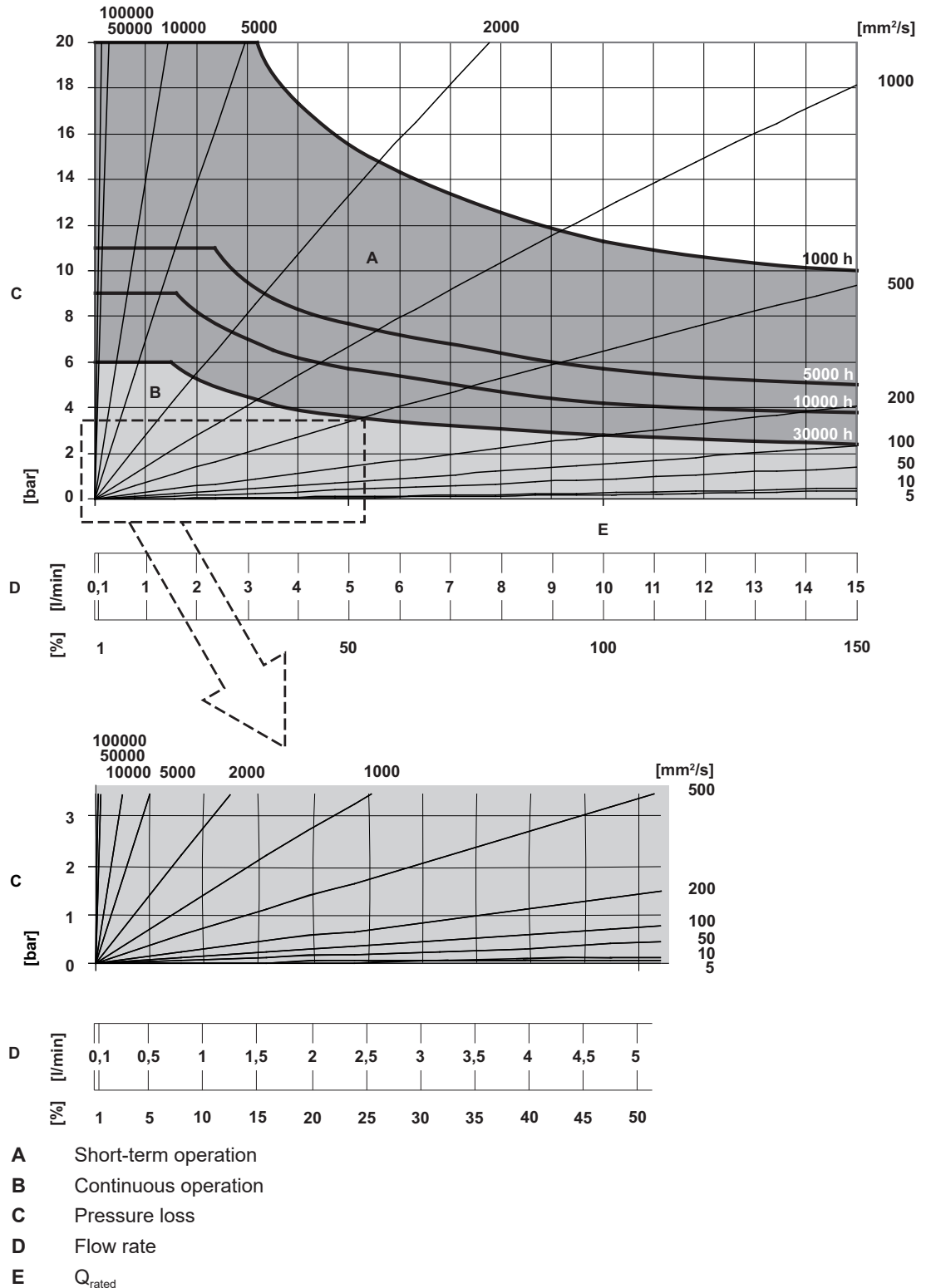

Notice The values apply for lubricating liquids at temperatures up to 120 °C. Abrasive and aggressive liquids reduce the service life.

4.7.2 Pressure bearing capacity OMG-020

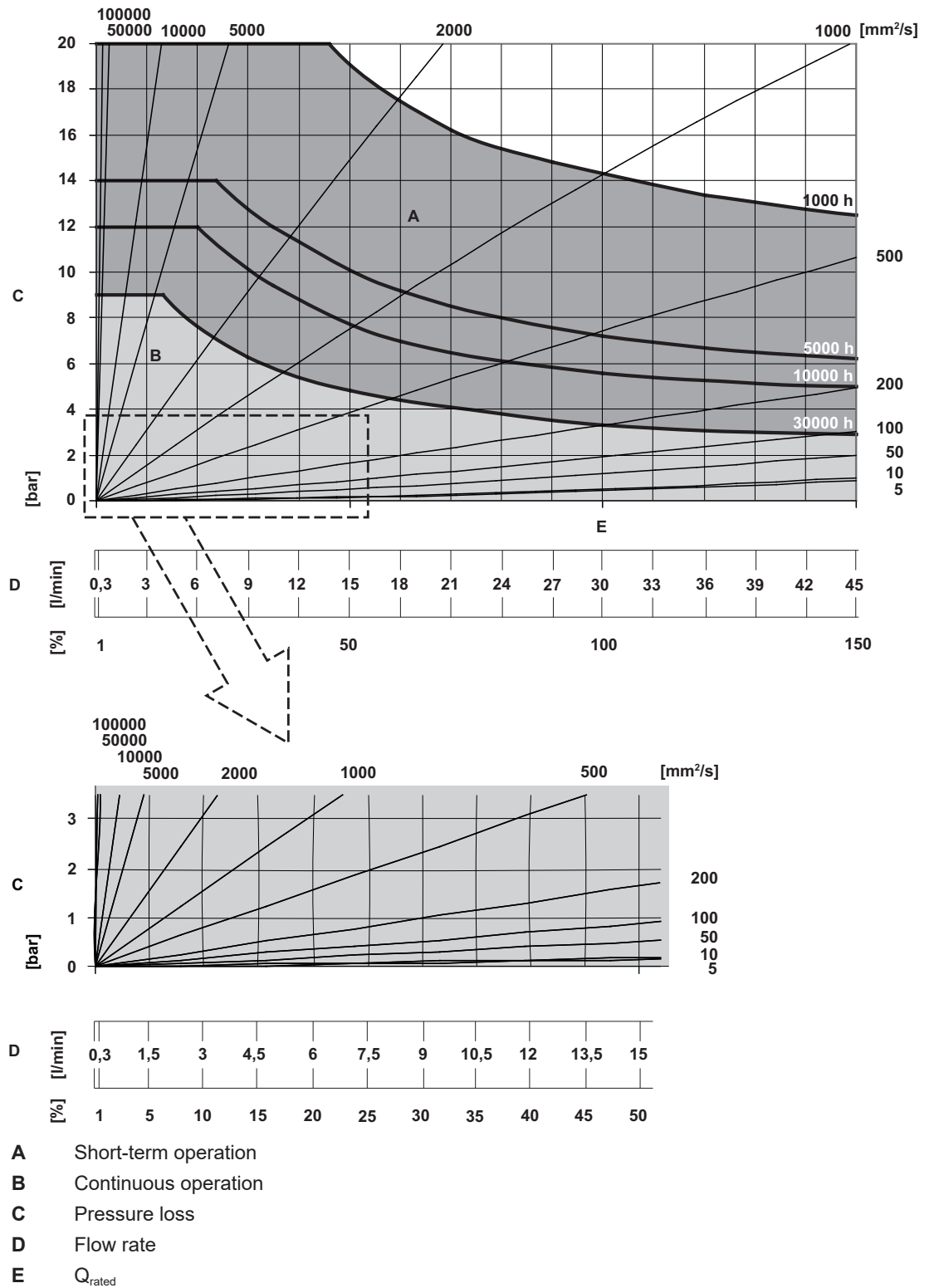

Notice The values apply for lubricating liquids at temperatures up to 120 °C. Abrasive and aggressive liquids reduce the service life.

4 Technical data

4.7 Pressure bearing capacity

4.7.3 Pressure bearing capacity OMG-032

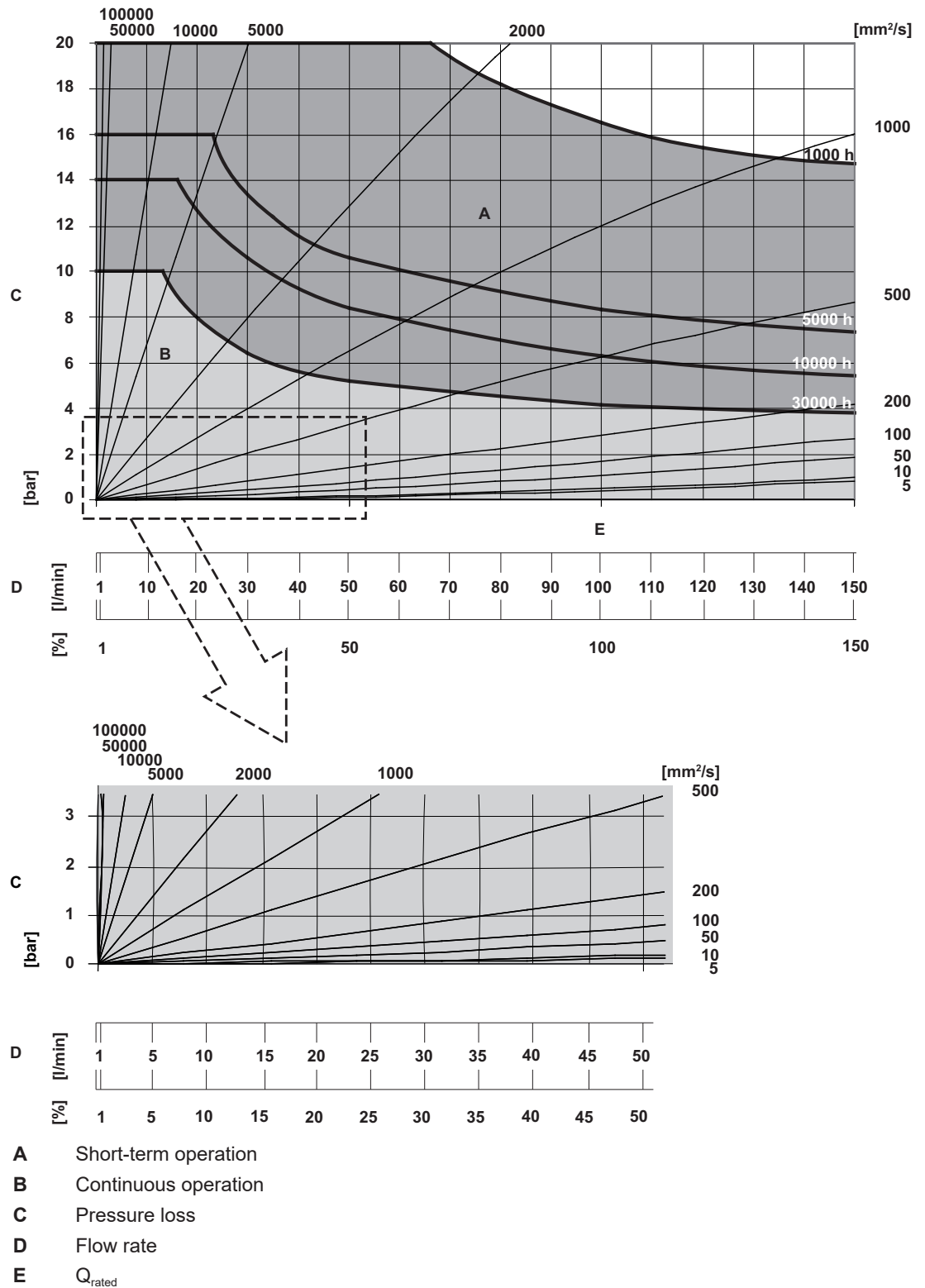

Notice The values apply for lubricating liquids at temperatures up to 120 °C. Abrasive and aggressive liquids reduce the service life.

4.7.4 Pressure bearing capacity OMG-052

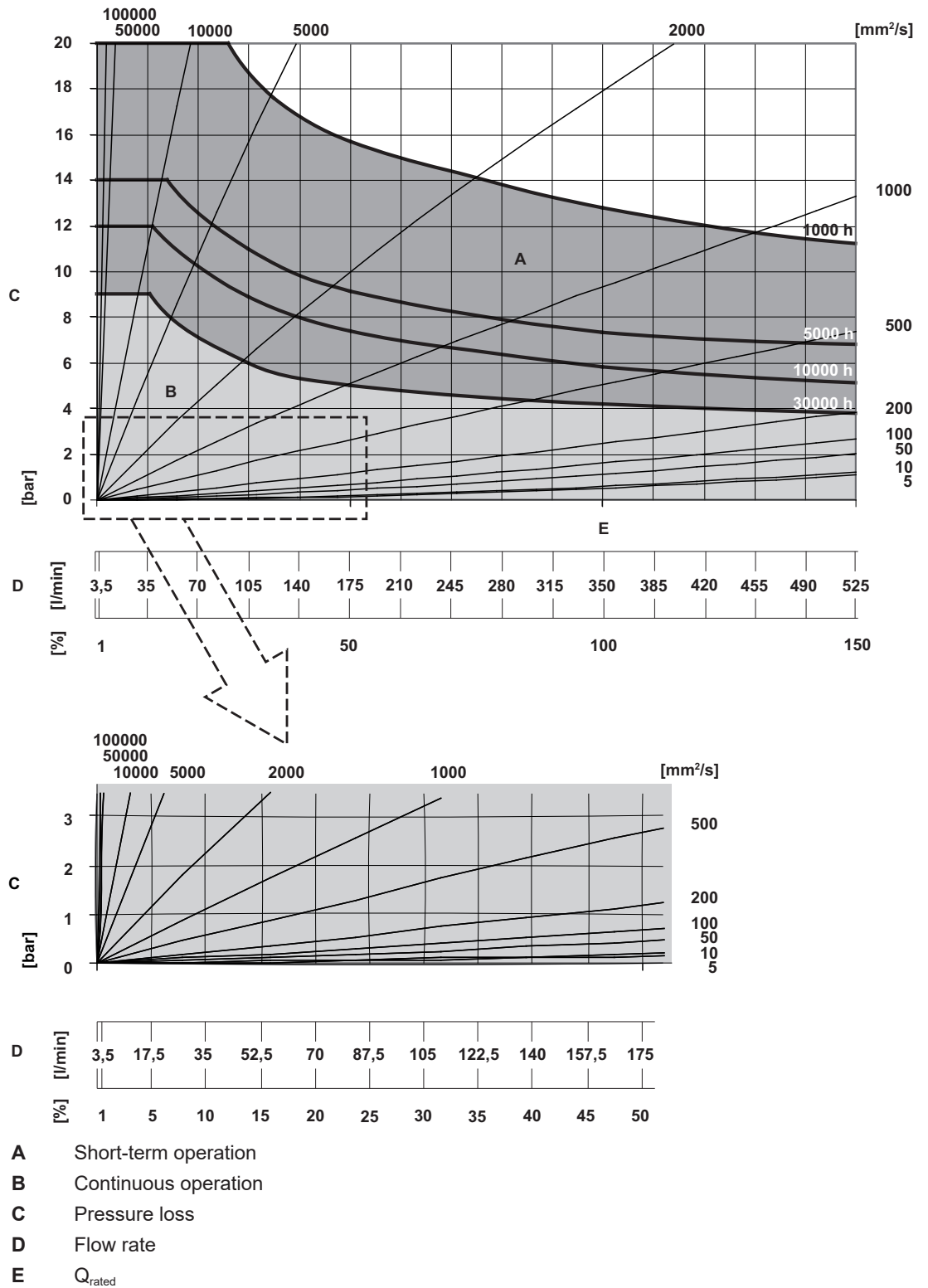

Notice The values apply for lubricating liquids at temperatures up to 120 °C. Abrasive and aggressive liquids reduce the service life.

4 Technical data

4.7 Pressure bearing capacity

4.7.5 Pressure bearing capacity OMG-068

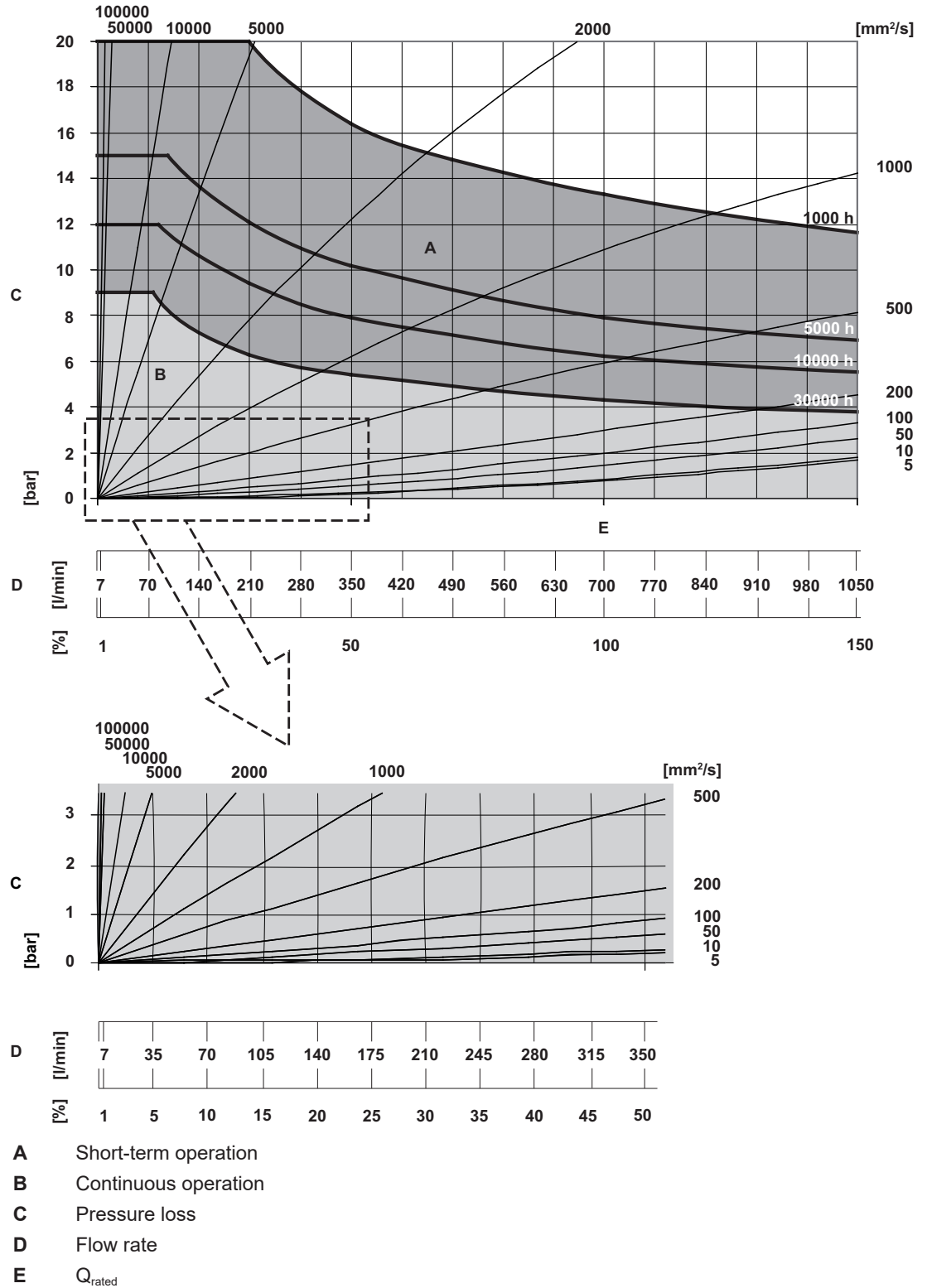

Notice The values apply for lubricating liquids at temperatures up to 120 °C. Abrasive and aggressive liquids reduce the service life.

4.7.6 Pressure bearing capacity OMG-100

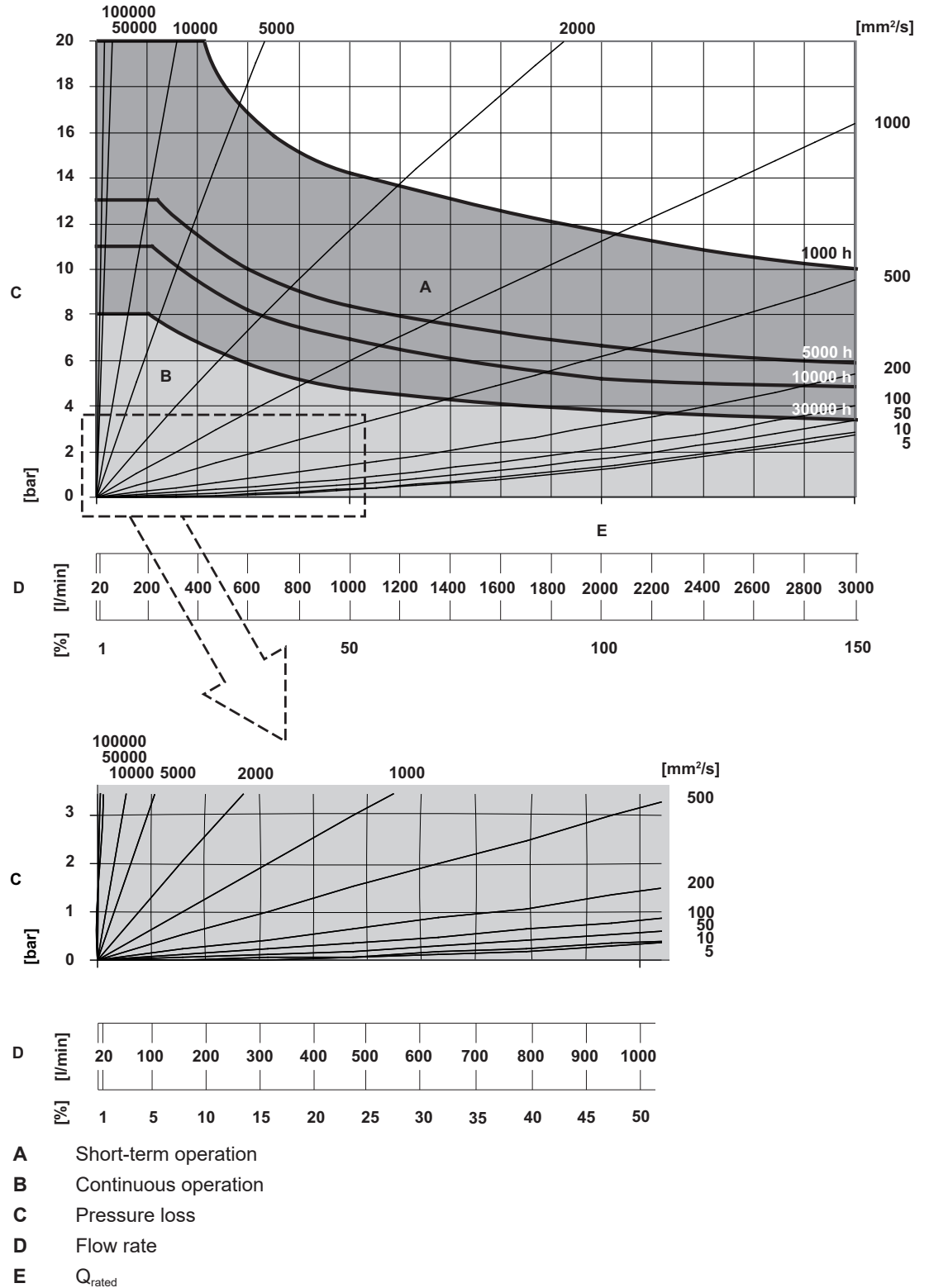

Notice The values apply for lubricating liquids at temperatures up to 120 °C. Abrasive and aggressive liquids reduce the service life.

4 Technical data

4.7 Pressure bearing capacity

4.7.7 Pressure bearing capacity OMG-140

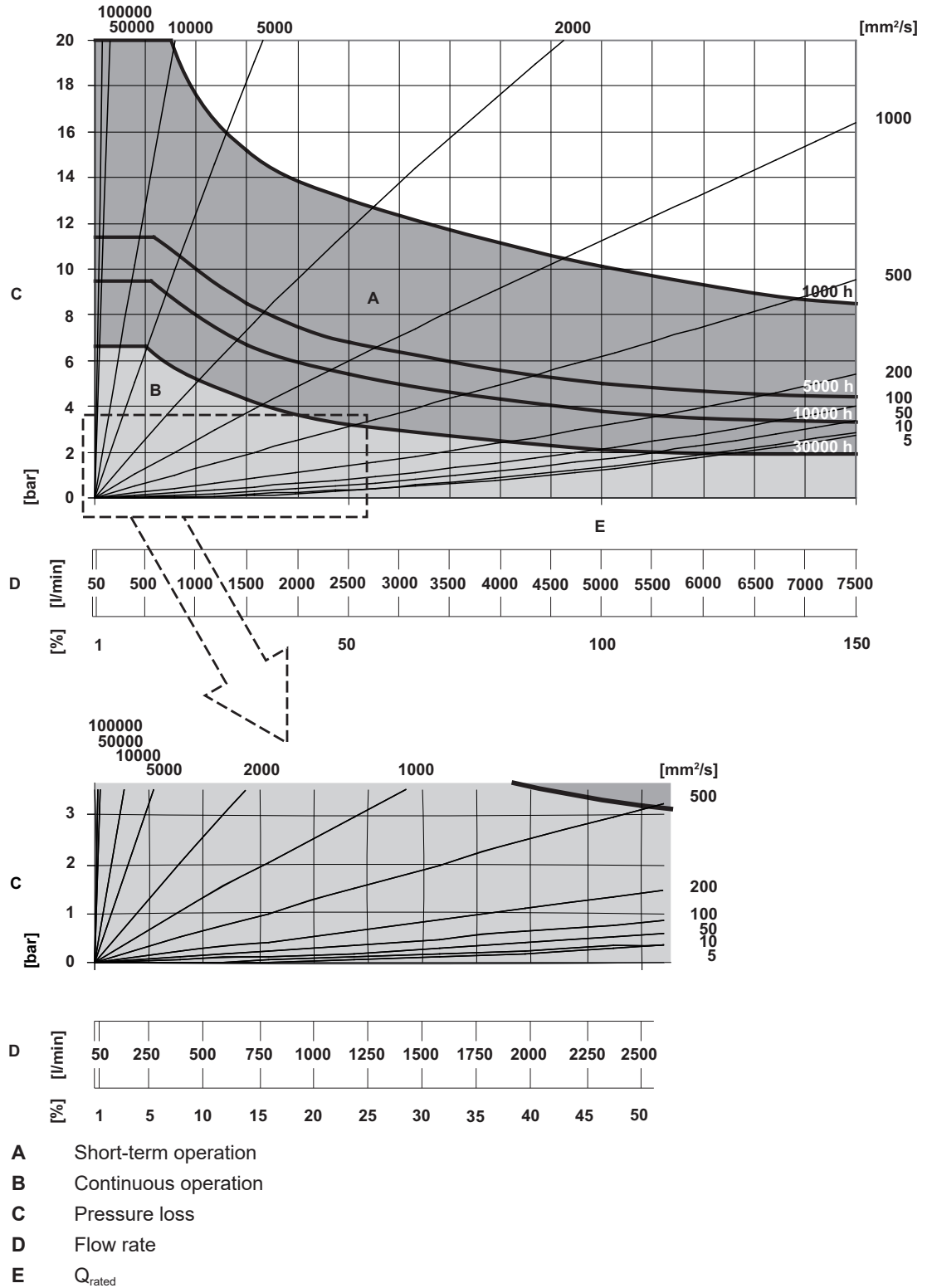

Notice The values apply for lubricating liquids at temperatures up to 120 °C. Abrasive and aggressive liquids reduce the service life.

5 Function description

5.1 Structure

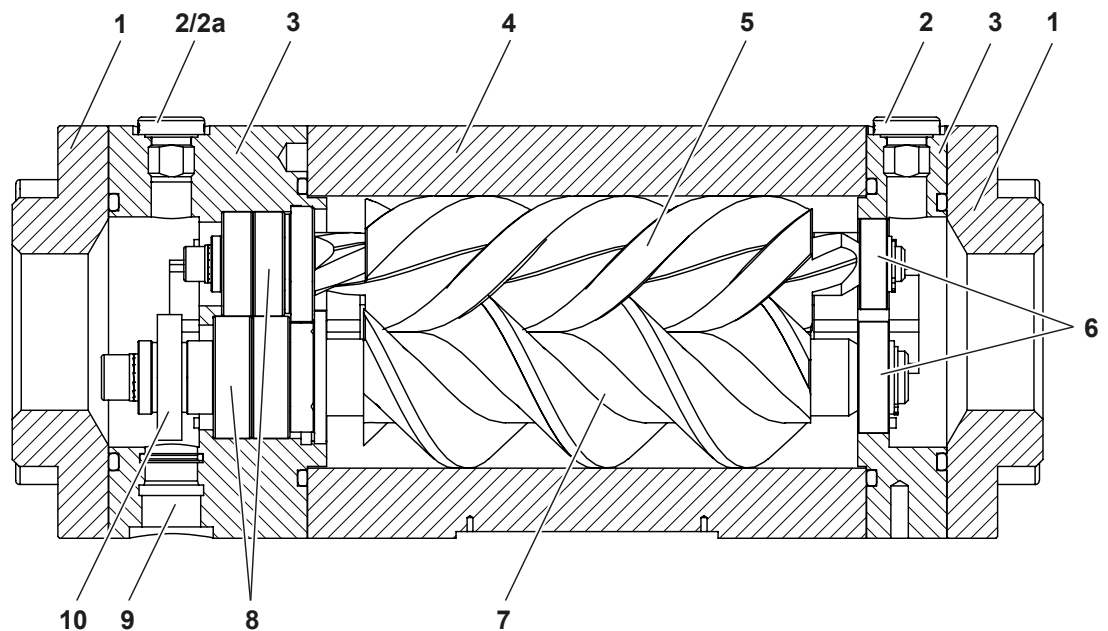

Fig. 6: Structure of the flowmeter

1	Connection	6	Ball bearing floating bearing end
2	Screw plug	7	Measuring screw large
2a	Connection of temperature sensor	8	Ball bearing fixed bearing end
3	Bearing cover	9	Pick up hole
4	Measuring housing	10	Pole wheel
5	Measuring screw small		

5.2 Functional principle

Flowmeters belong to the group of rotating displacement meters as screw meters. The pumped liquid makes the measuring unit rotate. The displacement effect results from the continuous filling, axial displacement and discharge of the volumes that are formed by the measuring housing and measuring unit. The measured pumped liquid flows around and lubricates all the rotating parts. Thanks to the displacement principle, the flowmeter does not require inlet sections and smoothing sections at the feed line and outlet.

Depending on the customer requirements, the flowmeters can be equipped with suitable end connections for connection to various flanges.

5.3 Rolling bearings

Thanks to precision rolling bearings the measuring unit operates contact-free and with low friction in the housing of the flowmeter. The bearing on the side of the pole wheel is realized as a fixed bearing.

The following bearings are used depending on the size:

- Single-row deep-groove ball bearings
- Angular-contact ball bearings arranged in pairs
- Four-point contact bearings

The bearing position on the opposite side of the measuring unit is realized for all sizes with a displaceable deep-groove ball bearing as a floating bearing.

5 Function description

5.4 Signal generation

5.4 Signal generation

A pole wheel **10** whose pole is sampled by a pick up is affixed at the fixed bearing end of the measuring screw large **7**. This pick up generates a specific number of pulses per flow volume unit – depending on the size and working point. This device-specific characteristic is called the K-factor (unit: Pulse/litre) and is specified on the rating plate as well as the enclosed calibration certificate.

Possible formats of the signals are:

- PNP
- Push-pull
- NAMUR

Depending on the version of the pick up, cylindrical pole wheels with embedded magnets or toothed metal disks with different tooth densities can be used (higher pole number = higher K-factor). Depending on the application (operating temperature, required frequencies) pick ups of different types can be used:

- Inductive pick ups
- Pick ups based on the Hall effect
- Magnetic pick ups

A preferred flow direction for which the pick up is located on the downstream side is specified on the rating plate of the flowmeter. This preferred direction results from the goal to position the pick up in case of a blockage of the flowmeter on the low-pressure side.

5.5 Linearization

The calibration certificate of the flowmeter contains a mean K-factor that has been determined for the flow range 10:1 and that can therefore be used across a wide flow range. However, the K-factor shows slightly different values at different flow rates. These are also documented in the enclosed calibration certificate. If highest measuring precision is required, it is therefore advisable, especially at strongly varying flow rates, to take these different values into consideration by means of a "Linearization". The K-factors are therefore stored in a suitable electronic unit by means of several interpolation values of the flow rate. The K-factor relevant for the flow rate being measured is then determined by means of linear interpolation between the two nearest interpolation values.

The viscosity dependence of the K-factors must also be taken into account. These are determined during calibration at a viscosity of approximately 4.2 mm²/s. The influence of the flow rate on the K-factor decreases at higher viscosities so that the mean K-factor can then also be used in a considerably larger flow range without noteworthy errors.

5.6 Temperature compensation

Flowmeters of the OMG series can be equipped additionally with temperature sensors for sizes OMG-013 to OMG-100. For size OMG-140 the installation of a temperature sensor is recommended. If the flowmeter is equipped with a temperature sensor, the current density of the flowing liquid can be calculated from the measured values by using a density table stored in the electronic unit. This allows standardised volume measurement in which the displayed values are converted to a reference temperature that can be selected freely. This ensures that measuring errors caused by changes in the density due to temperature variations are avoided.

5.7 Recognition of flow direction

Systems with a changing flow direction require the usage of a second pick up to recognize the change in direction. In the case of systems with pressure pulsation a reversal of the flow direction can also occur briefly.

The flow direction can be determined by means of the additional phase-shifted signal and the incremental encoder positions available in the KRAL electronic unit and then taken into account for the calculation of the total values.

6 Transportation, storage

6.1 Dangers during transportation



The following safety instructions must be observed:

- Have all work only carried out by authorized transport personnel.
- Use intact and correctly dimensioned hoisting equipment.
- Ensure that the means of transport is in a flawless state.
- Ensure that the centre of gravity of the load is taken into consideration.
- Do not stand under raised loads.

6.2 Dangers during storage



The following safety instructions must be observed:

- Observe the storage conditions.

6.3 Unpacking and checking the state of delivery

1. ➤ Upon delivery unpack the flowmeter and check it for damage during transportation.
2. ➤ Report damage during transportation immediately to the manufacturer.
3. ➤ Store the supplied sensors for the installation.
4. ➤ Dispose of packaging material in accordance with the locally applicable regulations.

6.4 Transporting flowmeters



⚠ WARNING

Risk of injury and damage to equipment through falling and toppling parts.

- ▶ Use intact and correctly dimensioned hoisting equipment in accordance with the total weight to be transported.
- ▶ Select the lift points for the hoisting equipment in accordance with the centre of gravity and the weight distribution.
- ▶ Use at least two load ropes.
- ▶ Do not stand under raised loads.

ATTENTION

Damage to equipment through improper transportation.

- ▶ Protect the flowmeter against damage, heat, sunlight, dust and moisture.

Requirement:

- ✓ Sufficiently dimensioned hoisting equipment
- ✓ The used hoisting equipment corresponding to the local rules and regulations for the prevention of accidents

7 Preservation

6.5 Storing the flowmeter

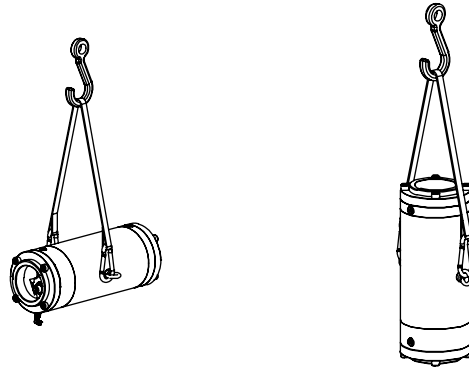

Fig. 7: Fastening of hoisting equipment - principle diagram

1. ► Fasten hoisting equipment on the flowmeter.
2. ► Transport the flowmeter to the installation location or temporary storage site.

6.5 Storing the flowmeter

As a result of the calibration, the internal components of the flowmeter are wetted with calibration liquid that has a preservative effect. In addition, a special anticorrosive agent is sprayed onto the interior of the flowmeter before being dispatched. The connections of the flowmeter are fitted with protective covers. The preservation applied at the factory will protect the flowmeter for up to six weeks, if it is stored in a dry and clean location. The manufacturer optionally offers a long-term preservation for storage times of up to 60 months. The flowmeter is additionally packed in hermetically sealing anti-corrosion paper.

ATTENTION

Damage to equipment and corrosion if stored improperly and during longer standstills.

- Protect the flowmeter against damage, heat, sunlight, dust and moisture.
- Protect against corrosion during longer standstill.
- Observe measures for storing and preservation.

1. ► Store cool and dry and protect against sunlight.
2. ► Observe the information on preservation.

7 Preservation

7.1 Preservation table

Preservation has to be carried out additionally under the following conditions:

Type of delivery	Condition
Standard delivery	<input type="checkbox"/> Storage time exceeding six weeks <input type="checkbox"/> Unfavourable storage conditions such as high humidity, salty air, etc.
Delivery with long-term preservation	<input type="checkbox"/> Opened or damaged packaging

Tab. 7: Conditions for additional preservation

Notice After a longer storage time the manufacturer recommends that you have the flowmeter recalibrated ↗ Maintenance, Page 31.

7.2 Preserving the inner surfaces

Personnel qualification:	<input type="checkbox"/> Trained personnel
Personal protective equipment:	<input type="checkbox"/> Work clothing <input type="checkbox"/> Protective gloves <input type="checkbox"/> Safety boots

Aids:	<input type="checkbox"/> Preservative (acid-free and resin-free oil)
<ol style="list-style-type: none"> 1. ➤ Close a connection of the flowmeter with a blind flange. 2. ➤ Position the flowmeter vertically. 3. ➤ Fill non-corrosive and resin-free oil into the pressure connection up to approx. 1 cm under the flange at the top while turning the measuring unit slowly, so that the measuring unit is also wetted. 4. ➤ Close the upper connection with a blind flange. 5. ➤ After about six months storage check the filling level of the oil and if necessary top up. 	

7.3 Preserving the outer surfaces

Personnel qualification:	<input type="checkbox"/> Trained personnel
Personal protective equipment:	<input type="checkbox"/> Work clothing <input type="checkbox"/> Protective gloves <input type="checkbox"/> Safety boots
Aids:	<input type="checkbox"/> Castrol Rustilo DWX 33 or other preservative offering comparable protection
<ol style="list-style-type: none"> 1. ➤ Paint or spray the preservative onto all plain and unpainted parts. 2. ➤ At intervals of about six months check the preservation and if necessary repeat. 	

7.4 Removing the preservation

Personnel qualification:	<input type="checkbox"/> Trained personnel
Personal protective equipment:	<input type="checkbox"/> Work clothing <input type="checkbox"/> Protective gloves <input type="checkbox"/> Safety boots
Aids:	<input type="checkbox"/> Solvent <input type="checkbox"/> Collection tank



⚠ CAUTION

Risk of injury through emitted preservative.

- ▶ Wear personal protective clothing during all the work.
- ▶ Collect any discharging preservative safely and dispose of it in an environmentally compatible manner in accordance with the applicable local regulations.

1. ➤ Remove one of the blind flanges.
2. ➤ Drain the flowmeter, collecting the preservative oil in a suitable vessel.
3. ➤ Remove the second blind flange.
4. ➤ Either remove the residual oil with solvent or flush the flowmeter with pumped liquid.

8 Installation, removal

8.1 Dangers during installation

8 Installation, removal

8.1 Dangers during installation



The following safety instructions must be observed strictly:

- Have all work only carried out by authorized qualified personnel.
- Do not take apart the flowmeter.
- Do not remove the protective caps from the dry sleeves.

8.2 Dangers during removal



The following safety instructions must be observed strictly:

- Have all work only carried out by authorized qualified personnel.
- Ensure that the collection tank for emitted liquids is sufficiently large.
- Collect any discharging pumped liquid safely and dispose of it in an environmentally compatible manner in accordance with the applicable local regulations.
- Place the protective caps onto dry sleeves.

8.3 Installing the flowmeter

8.3.1 Protecting the flowmeter against soiling

Notice Soiling in the pipe system impairs the service life of the flowmeter. In order to protect the flowmeter against soiling the manufacturer generally recommends the installation of an operating filter.

Personnel qualification:	<input type="checkbox"/> Fitter
Personal protective equipment:	<input type="checkbox"/> Work clothing <input type="checkbox"/> Protective gloves <input type="checkbox"/> Safety boots

ATTENTION

Damage to device through solid particles in the pipe system.

- ▶ During welding work attach protective covers in front of the connecting flanges.
- ▶ Ensure when welding that welding beads and abrasive dust cannot get into the pipe system and the flowmeter.
- ▶ Ensure that an operating filter is installed when the pipe system is flushed and cleaned using the flowmeter.

1. ▶ Install the operating filter in front of the flowmeter, mesh width ↪ Commissioning, Page 29.
2. ▶ After the connecting work clean the pipe system thoroughly ↪ Commissioning, Page 29.

8.3.2 Installation types

Flowmeters can be operated in different installation positions.

Both flow directions are possible. The preferred flow direction is indicated on the rating plate by means of a bright arrow ↪ Identification, Page 6.

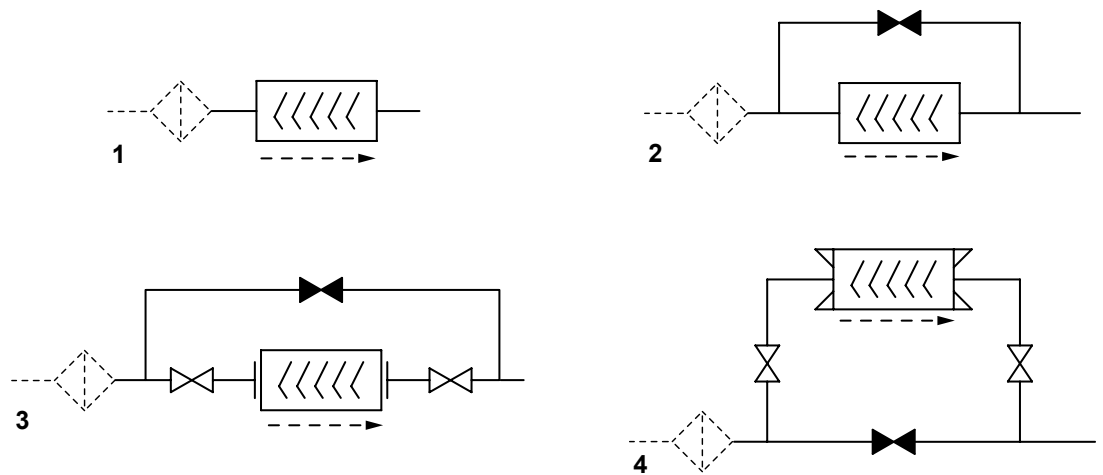

Fig. 8: Installation types

The arrow with dashed line identifies the preferred flow direction when an operating filter is used.

Installation type		Properties
1	<input type="checkbox"/> Without bypass <input type="checkbox"/> With or without operating filter	<input type="checkbox"/> Small space requirements <input type="checkbox"/> Dismantling of the flowmeter only with operation interruption
2	<input type="checkbox"/> Manual bypass <input type="checkbox"/> With or without operating filter	<input type="checkbox"/> Manual opening of the bypass <input type="checkbox"/> Dismantling of the flowmeter only with operation interruption
3	<input type="checkbox"/> Bypass with 3 shut-off valves for flange connection <input type="checkbox"/> With or without operating filter	<input type="checkbox"/> Dismantling of the flowmeter without operation interruption
4	<input type="checkbox"/> Bypass with 3 shut-off valves for pipe thread connection <input type="checkbox"/> With or without operating filter	<input type="checkbox"/> Dismantling of the flowmeter without operation interruption <input type="checkbox"/> Minimal higher pressure loss

Tab. 8: Installation types

8.3.3 Installation recommendation

In order to avoid measuring errors observe the following recommendations of the manufacturer when installing the flowmeter in the pipe system.

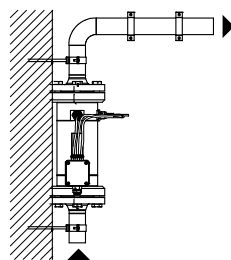

Preferred installation variant:

- Install the flowmeter vertically.
- Route the flow from the bottom upwards.

Recommendations for alternative installation variants

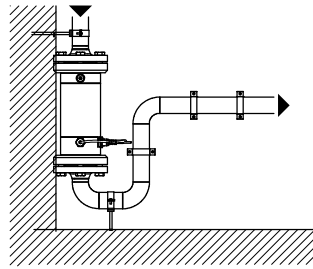

Alternative installation variant:

- Install the flowmeter vertically.
- Route the flow from the top downwards.
- Route the piping at the outlet upwards.

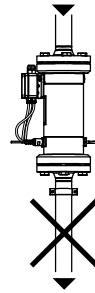

Source for measuring error:

- Lack of counter-pressure at the outlet through downv

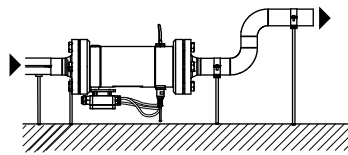

Alternative installation variant:

- Install the flowmeter horizontally.
- Route the piping at the outlet upwards.

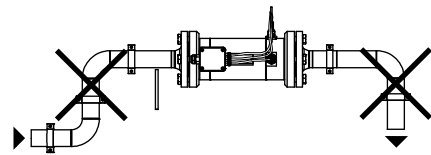

Source for measuring error:

- Formation of an air pocket through the installation o

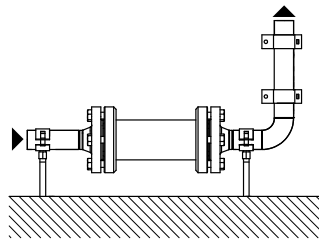

Recommendation:

- Carefully vent the pipe system during commissioning.
- Gas inclusions in the pipe system

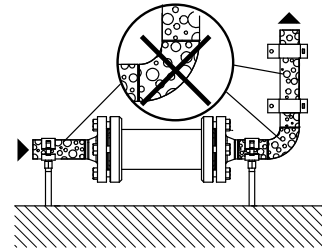

Source for measuring error:

8.3.4 Installing the flowmeter

Personnel qualification:	<input type="checkbox"/> Fitter
Personal protective equipment:	<input type="checkbox"/> Work clothing <input type="checkbox"/> Protective gloves <input type="checkbox"/> Safety boots

ATTENTION

Measuring error through air pocket in the flowmeter.

- ▶ During installation ensure that the flowmeter is not installed at the highest point in the pipe system.

ATTENTION

Measuring error through a lack of counter-pressure.

- ▶ During the installation ensure that the piping at the outlet of the flowmeter runs upwards or that the pipe diameter is reduced through a reducer so that the liquid generates a counter-pressure.

- ➔ During the installation of the flowmeter observe the recommendations for the installation variants and avoid error sources.

8.4 Removing the flowmeter

Personnel qualification:	<input type="checkbox"/> Fitter <input type="checkbox"/> Electrician
Personal protective equipment:	<input type="checkbox"/> Work clothing <input type="checkbox"/> Face protection <input type="checkbox"/> Protective gloves <input type="checkbox"/> Safety boots
Aids:	<input type="checkbox"/> Collection tank



DANGER

Risk of death resulting from electric shock.

- ▶ Ensure that the electrical power supply is de-energized and is secured against being switched back on.
- ▶ Observe the operating instructions of the electrical components.



DANGER

Risk of death through emitted pumped liquid.

Pumped liquids can be hot, poisonous, combustible and caustic and can spray out under high pressure.

- ▶ Wear personal protective equipment during all the work. Ensure face protection.
- ▶ Before beginning work, let the flowmeter cool down to the ambient temperature.
- ▶ Ensure that the flowmeter is depressurized.
- ▶ Collect any discharging pumped liquid safely and dispose of it in an environmentally compatible manner in accordance with the applicable local regulations.

Requirement:

- ✓ System switched off
 - ✓ Disconnect the system from the power supply and secure it against being switched back on
 - ✓ Flowmeter cooled down to the ambient temperature
1. ▶ Drain the pipe system or divert the pumped liquid via bypass.
 2. ▶ Remove the flowmeter.
 3. ▶ Attach protective covers in front of connecting flanges.
 4. ▶ For storage of the flowmeter ↪ Transportation, storage, Page 21 and ↪ Preservation, Page 22.

9 Connection

9.1 Dangers during connection work



The following safety instructions must be observed strictly:

- Have all the work on the flowmeter and pipe system only carried out by authorized qualified personnel.
- Ensure that solid particles cannot get into the flowmeter and pipe system.
- Ensure that mechanical connections are mounted free of stress.
- Observe the tightening torques.
- Have all the work on the electrical equipment only carried out by electricians.
- Before beginning work on the flowmeter ensure that the electrical power supply is deenergized and is secured against being switched back on.
- If the insulation of the electrical cables or wires is damaged, disconnect the power supply immediately.
- The connecting line of the pick up/temperature sensor connection is to be shielded and laid separately from the supply lines.

9.2 Connecting the flowmeter to the pipe system

Personnel qualification:	<input type="checkbox"/> Fitter
Personal protective equipment:	<input type="checkbox"/> Work clothing <input type="checkbox"/> Protective gloves <input type="checkbox"/> Protective helmet <input type="checkbox"/> Safety boots
Aids:	<input type="checkbox"/> Hoisting equipment

ATTENTION

Damage to device through mechanical stress.

- ▶ Ensure that the flowmeter is mounted free of mechanical stresses in the pipe system.
- ▶ Observe the tightening torques.

ATTENTION

Damage to device through solid particles in the pipe system.

- ▶ During welding work attach protective covers in front of the connecting flanges.
- ▶ Ensure when welding that welding beads and abrasive dust cannot get into the pipe system and the flowmeter.
- ▶ Ensure that an operating filter is installed when the pipe system is flushed and cleaned using the flowmeter.

ATTENTION

Damage to device when the pipe threading is screwed in too far.

- ▶ Observe the thread length of the flowmeter.
- ▶ Use a standard cutting ring screw connection.

Notice The screw-in length of the piping may not exceed the threaded length of the flowmeter, since the flow cross-section is narrowed and internal components can be damaged.

1. ▶ Remove the protective covers and store them.
2. ▶ Place the piping in position and support the weight of the piping.
3. ▶ Install the flowmeter stress-free into the pipe system. In the process take the preferred flow direction into account and ensure that the connections of the pick up remain accessible.

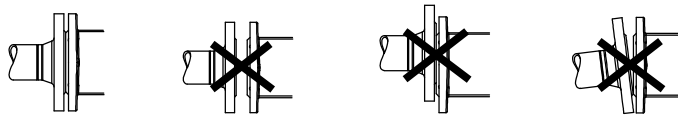

4. ▶ Check the linear offset, lateral offset and angular offset and correct if necessary. If the screws tighten easily, this is a sure sign that the installation is stress-free.
5. ▶ Tighten the connecting screws crosswise with torque ↪ Appendix, Page 54.

9.3 Connecting the pick up

The flowmeter is equipped with two pick ups to enable recognition of the flow direction. The first signal measures the flow rate, the second signal determines the flow direction. In order to obtain correct values the pick ups must be connected correctly. The connections are identified with "1" and "2" on the housing of the flowmeter. This marking depends on the preferred flow direction according to the arrow on the rating plate ↪ Identification, Page 6.

In the case of a flow direction contrary to the preferred flow direction the connections have to be swapped in order to obtain a correct signal.

ATTENTION**Measuring error through incorrectly installed pick ups.**

- ▶ Ensure that pick ups are installed at the correct position.
- ▶ The connecting line of the pick up/temperature sensor connection is to be shielded and laid separately from the supply lines.
- ▶ Ensure that the power supply is correct.

→ Connect pick ups in accordance with the identification on the flowmeter. Observe the associated operating instructions for pick ups.

10 Operation**10.1 Dangers during operation****The following safety instructions must be observed strictly:**

- Have all work only carried out by authorized qualified personnel.
- Ensure that the flowmeter is only operated within the operating limits.
- Ensure that during cooling down or heating up the flowmeter is only subjected to slow temperature changes.
- Ensure that existing safety equipment is not bypassed or activated during operation.

10.2 Commissioning**10.2.1 Cleaning the pipe system**

Notice Soiling in the pipe system impairs the service life of the flowmeter. In order to protect the flowmeter against soiling the manufacturer generally recommends the installation of an operating filter.

Notice Through the calibration, the internal components of the flowmeter are wetted with calibration liquid. If required, use an appropriate solvent to flush the flowmeter.

ATTENTION**Damage to device through usage of an incorrect flushing liquid.**

- ▶ Under no circumstances may water or superheated steam be used to flush the pipe system.

→ **Flushing via bypass:** Close the shut-off devices before and after the flowmeter.

- or -

→ **Flushing via flowmeter:** Install the operating filter in front of the flowmeter, while observing the mesh width of the operating filter, see the following table.

The mesh width of the operating filter is relevant to the size of the flowmeter.

Size of the flowmeter	Unit	Max. mesh width
OMG-013 – OMG-020	[mm]	0.1
OMG-032 – OMG-140	[mm]	0.25

Tab. 9: Mesh width of the operating filter

10.2.2 Checking the function

1. → Check the flow direction of the flowmeter.
2. → Check the installation and installation position of the pick up and of the temperature sensor.
3. → Check leaks at the pipe thread/connecting flange.
4. → Check the electrical installation. Observe the operating instructions for pick up and electronic unit.
5. → Check the power supply. Observe the operating instructions for pick up and electronic unit.

10.2.3 Commissioning the flowmeter

ATTENTION

Increased wear and/or blockade through solid particles or abrasive fine particles in the liquid.

- ▶ Protect the flowmeter through correspondingly dimensioned operating filters in the pipe system.

ATTENTION

Measuring error when the pressure drops below the minimum pressure outlet at the outlet.

- ▶ Ensure that sufficient counter-pressure exists at the outlet by routing the piping upwards.

ATTENTION

Measuring error through gas inclusion in the pipe system.

- ▶ Before commissioning, make sure that the flowmeter is filled.
- ▶ Vent the pipe system.

Requirement:

- ✓ The ambient conditions correspond to the operating data
- ✓ Flowmeter installed correctly in the pipe system ↪ Installation, removal, Page 24
- ✓ Flowmeter connection to the pipe system is stress-free
- ✓ Pipe system is free of impurities
- ✓ Pipe system vented
- ✓ Shut-off devices in the feed line and outlet opened

—▶ Switch on the measuring system.

- ⇒ The flowmeter measures when the pick up generates a signal.

10.3 Decommissioning

10.3.1 Switching off the flowmeter

ATTENTION

Damage to the measuring unit.

In the case of strong changes to the flow rate (for example, rapid shutdown, pulsations, etc.) there is a danger of excessive pressure differences.

- ▶ Ensure that the pressure loss of the flowmeter does not exceed the values specified on the rating plate or the substitute operating data.

—▶ Ensure that the pressure loss of the flowmeter does not exceed the values specified on the rating plate or the standardized substitute operating data ↪ Technical data, Page 8.

- ⇒ When the flow through the flowmeter is stopped, the generation of the signal stops automatically. No further measures are required to switch off.

10.4 Recommissioning

10.4.1 Recommissioning the flowmeter

ATTENTION

Damage to device through hard, gummy or crystallized pumped liquid in the flowmeter.

- ▶ Before recommissioning, ensure that there is no hard, gummy or crystallized pumped liquid in the flowmeter.

Requirement:

- ✓ The ambient conditions correspond to the operating data
- ✓ Flowmeter connection to the pipe system is stress-free
- ✓ Pipe system is free of solid particles
- ✓ Pipe system vented
- ✓ Shut-off devices in the feed line and outlet opened

—▶ Switch on the system.

⇒ The flowmeter is ready to operate.

11 Maintenance

11.1 Required maintenance

Flowmeters are fundamentally maintenance-free. Under observance of the operating limits ↗ Technical data, Page 8, no significant change in the characteristics could be established, even after years of use in many cases. Stresses lying clearly above the rated flow rate can, however, result in excessive wear. In the case of liquids with higher abrasiveness (for example heavy fuel oil with catalyst residues, plastic components with fillers, etc.) strongly accelerated wear can occur in the flowmeter.

Notice In cases of doubt the manufacturer recommends already carrying out the first inspection after twelve weeks operation time.

11.2 Maintaining flowmeters

The following table lists signs of progressive wear of individual elements of the flowmeter:

Finding	Cause	Elimination
Increased running noises	Incipient damage to bearing	—▶ Replace the bearing.
Leakage	Damage to sealing	—▶ Replace the seals or dry sleeve.
Measured values not realistic	↗ Troubleshooting, Page 42	—▶ ↗ Troubleshooting, Page 42

Tab. 10: Check table for required maintenance

Personnel qualification:	<input type="checkbox"/> Fitter
Personal protective equipment:	<input type="checkbox"/> Work clothing <input type="checkbox"/> Face protection <input type="checkbox"/> Protective gloves <input type="checkbox"/> Safety boots



WARNING

Risk of injury through emitted pumped liquid.

Pumped liquids can be hot, poisonous, combustible and caustic.

- ▶ Wear personal protective clothing during all the work. Ensure face protection.
- ▶ Collect any discharging pumped liquid safely and dispose of it in an environmentally compatible manner in accordance with the applicable local regulations.

1. ▶ Check the flowmeter visually and acoustically every four weeks.
2. ▶ Check for signs of wear as listed in the table above and eliminate the cause.

11.3 Recalibration of the flowmeter

In order to maintain the high measuring precision of the flowmeter, the manufacturer recommends carrying out the first recalibration after about one year of operation. The results reveal any wear starting on the measuring unit. The interval at which recalibrations are actually required depends strongly on the operating conditions of the flowmeter.

The manufacturer provides the factory calibration as standard. If higher requirements are placed on the flowmeter, accredited calibration in accordance with EN/ISO/IEC 17025 is also possible.

12 Servicing

12.1 Dangers during servicing



The following safety instructions must be observed strictly:

- Have all work only carried out by authorized qualified personnel.
- To ensure the measuring precision, the measuring unit may only be replaced by the manufacturer.
- Before beginning work, let the flowmeter cool down slowly to the ambient temperature. Avoid rapid temperature changes.
- Pumped liquids can be hot, poisonous, combustible and caustic.
- Observe the tightening torques ↪ Appendix, Page 54.
- Observe the operating instructions and data sheets of the sensors.

12.2 Replacing seals and ball bearings

12.2.1 Removing seals and ball bearings OMG-013

Personnel qualification:	<input type="checkbox"/> Fitter
Personal protective equipment:	<input type="checkbox"/> Work clothing <input type="checkbox"/> Protective gloves <input type="checkbox"/> Safety boots
Aids:	<input type="checkbox"/> Extractor

Requirement:

- ✓ Flowmeter removed from system
- ✓ Completion consisting of socket screws, flanges and seals removed
- ✓ Pick up inserts removed

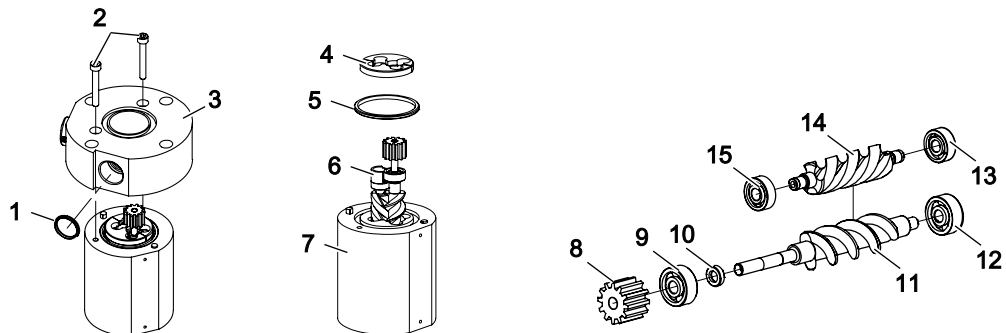

1. ➤ Remove the socket screws **2**, take off the bearing cover **3** and O-ring **1** from the pick up hole in the bearing cover.
2. ➤ Remove the spacer **4** and O-ring **5** and pull the screw set together with the distance sleeve **6** from the measuring housing **7**.
3. ➤ Use the extractor to pull off the pole wheel **8**, ball bearings **9** and **12** from the measuring screw large **11** and remove the sleeve **10**.
4. ➤ Use the extractor to pull the ball bearings **15** and **13** from the measuring screw small **14**.

12.2.2 Installing seals and ball bearings OMG-013

Personnel qualification:	<input type="checkbox"/> Fitter
Personal protective equipment:	<input type="checkbox"/> Work clothing <input type="checkbox"/> Protective gloves <input type="checkbox"/> Safety boots
Aids:	<input type="checkbox"/> Torque wrench

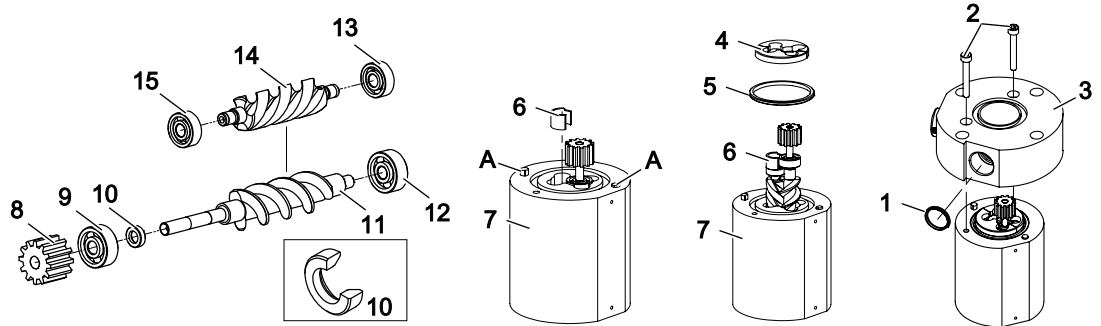

1. ➤ Slide the sleeve **10** onto the measuring screw large **11**. Observe the installation direction.
2. ➤ Press on the ball bearings **9** and **12** over the inner ring of the ball bearing onto the measuring screw large **11**.
3. ➤ Press the pole wheel **8** onto the measuring screw large **11**.
4. ➤ Press on the ball bearings **13** and **15** over the inner ring of the ball bearing on the measuring screw small **14**.
5. ➤ Carefully slide the screw set into the measuring housing **7**.
6. ➤ Slide the distance sleeve **6** into the hole of the measuring screw small **14**.
7. ➤ Insert the O-ring **5** into the measuring housing **7** and place the spacer **4**.
8. ➤ Insert the O-ring **1** into the pick up hole in the bearing cover **3**.
9. ➤ Place the bearing cover **3** onto the measuring housing **7**. Please ensure that the tapered dowel pins **A** in the measuring housing match the fitting holes in the bearing cover.
10. ➤ Tighten the socket screws **2** with torque.

12.2.3 Removing seals and ball bearings OMG-020/OMG-032

Personnel qualification:	<input type="checkbox"/> Fitter
Personal protective equipment:	<input type="checkbox"/> Work clothing <input type="checkbox"/> Protective gloves <input type="checkbox"/> Safety boots
Aids:	<input type="checkbox"/> Extractor

Requirement:

- ✓ Flowmeter removed from system
- ✓ Completion consisting of socket screws, flanges and seals removed
- ✓ Pick up inserts removed

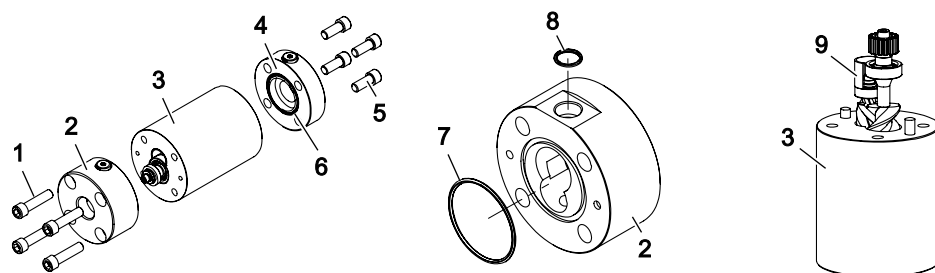

1. ➤ Remove the socket screws **1**, take off the end cover **2** and O-rings **7** and **8**.
2. ➤ Remove the socket screws **5**, take off the end cover **4** and O-ring **6**.
3. ➤ Remove the screw set together with the distance sleeve **9** from the measuring housing **3**.

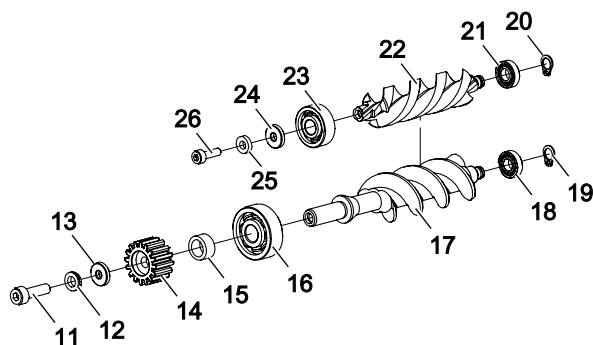

4. ➤ Remove the circlip **19** from the measuring screw large **17** and remove the circlip **20** from the measuring screw small **22**.
5. ➤ Unscrew the socket screw **26**, remove the wedge lock washers **25** and supporting ring **24**.
6. ➤ Unscrew the socket screw **11**, remove the wedge lock washers **12** and supporting ring **13**.
7. ➤ Screw the socket screw **11** completely back in, in order to pull the pole wheel **14** from the measuring screw large **17** by using an extractor.
8. ➤ Remove the distance ring **15** and remove the socket screw **11** again.
9. ➤ Use the extractor to pull off the ball bearings **16** and **18** from measuring screw large **17**.
10. ➤ Use the extractor to pull the ball bearings **23** and **21** from the measuring screw small **22**.

12.2.4 Installing seals and ball bearings OMG-020/OMG-032

Personnel qualification:	<input type="checkbox"/> Fitter
Personal protective equipment:	<input type="checkbox"/> Work clothing <input type="checkbox"/> Protective gloves <input type="checkbox"/> Safety boots
Aids:	<input type="checkbox"/> Torque wrench

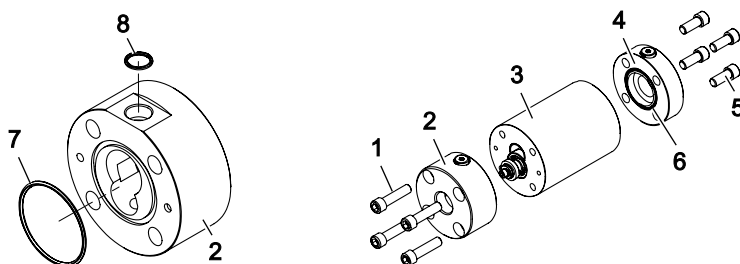

1. ➤ Insert the O-ring **7** into the end cover **2** and insert the O-ring **8** into the pick up hole in the end cover.
2. ➤ Insert the O-ring **6** into the end cover **4**.

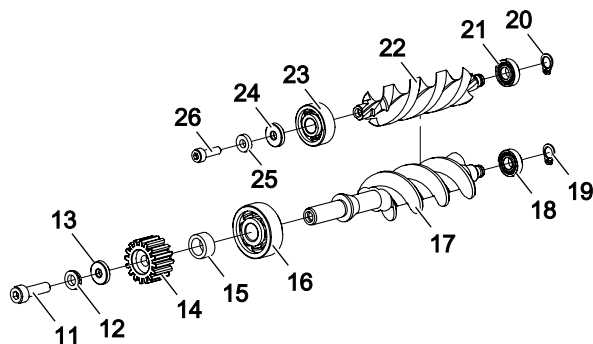

3. ➤ Press on the ball bearings **16** and **18** over the inner rings on the measuring screw large **17**.
4. ➤ Press on the ball bearings **23** and **21** over the inner ring of the ball bearing on the measuring screw small **22**.
5. ➤ Slide the distance ring **15** on the measuring screw large **17** and press on the pole wheel **14**.
6. ➤ Pull the wedge lock washers **12** and supporting ring **13** onto the socket screw **11**. Ensure the correct positioning of the wedge lock washers (wedge on wedge).
7. ➤ Apply Loctite 242 to the socket screw **11** and install on the measuring screw large **17**.

8. ➤ Pull the wedge lock washers **25** and supporting ring **24** onto the socket screw **26**. Ensure the correct positioning of the wedge lock washers (wedge on wedge).
9. ➤ Apply Loctite 242 to the socket screw **26** and install on the measuring screw small **22**.
10. ➤ Install the circlips **19** and **20** on the floating bearing end.

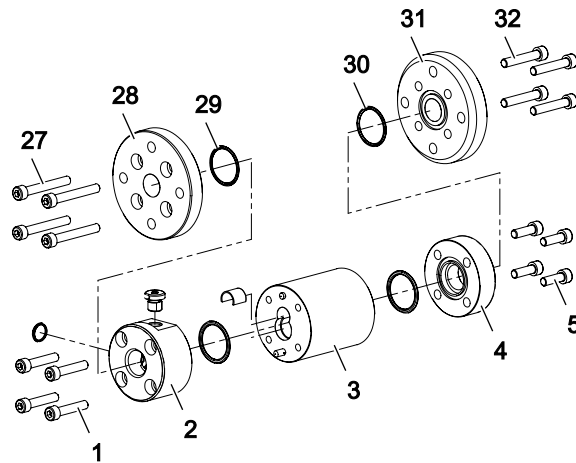

11. ➤ **At a pipe thread connection:** Place the end cover **4** on the measuring housing **3**, lay ready the socket screws **5**.
-or-
At a flange connection: Place the end cover **4** and flange cover **31** with O-ring **30** on the measuring housing **3**, lay ready the socket screws **32**.
12. ➤ Pretension the oiled screws crosswise and tighten with torque.

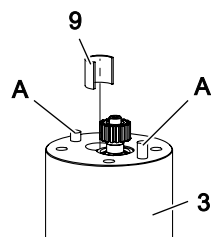

13. ➤ Carefully slide the screw set into the measuring housing **3**.
14. ➤ Slide the distance sleeve **9** into the hole of the measuring screw small **22**.

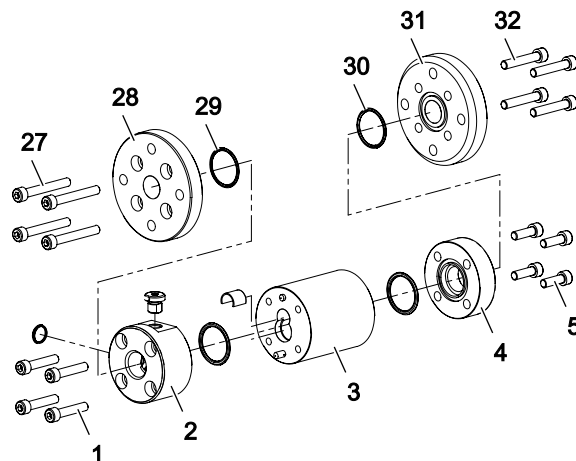

15. ➤ Place the end cover **2** onto the measuring housing. Please ensure that the tapered dowel pins **A** in the measuring housing match the fitting holes.
16. ➤ **At a BSPP connection:** Lay ready the socket screws **1**.
- or -
At a flange connection: Place on the flange cover **28** with O-ring **29** and lay ready the socket screws **27**.
17. ➤ Pretension the oiled screws crosswise and tighten with torque.

12.2.5 Removing seals and ball bearings OMG-052/OMG-068

Personnel qualification:	<input type="checkbox"/> Fitter
Personal protective equipment:	<input type="checkbox"/> Work clothing <input type="checkbox"/> Protective gloves <input type="checkbox"/> Safety boots
Aids:	<input type="checkbox"/> Plastic hammer <input type="checkbox"/> Extractor

Requirement:

- ✓ Flowmeter removed from system
- ✓ Completion consisting of socket screws, flanges and seals removed
- ✓ Pick up inserts removed

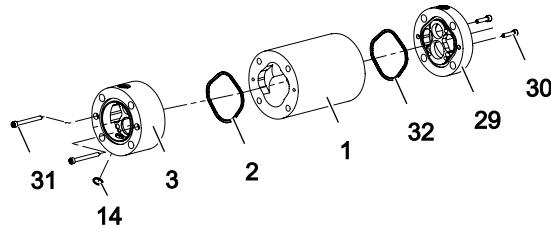

1. ➔ Remove the socket screws 31 and 30, take off the bearing cover 29 and remove the O-ring 32.

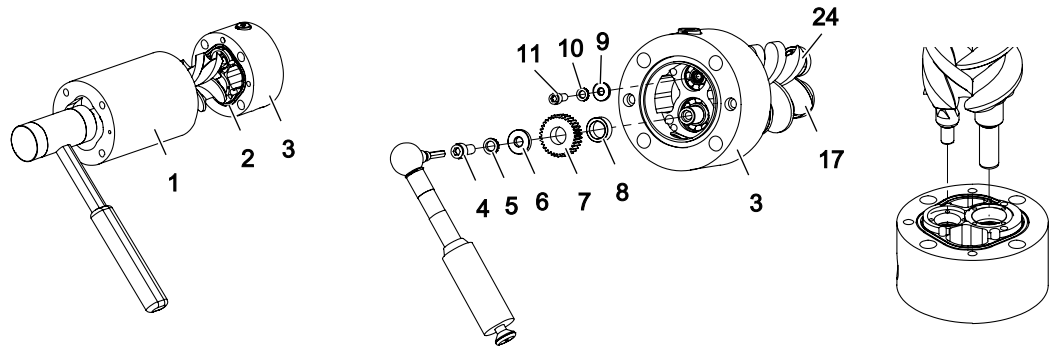

2. ➔ Drive the screw set together with the bearing cover 3 out of the measuring housing 1 using light blows of a plastic hammer and pull out.

3. ➔ Remove the O-ring 2 from the bearing cover 3.

4. ➔ Unscrew the socket screw 4, remove the wedge lock washers 5 and supporting ring 6.

5. ➔ Unscrew the socket screw 11, remove the wedge lock washers 10 and supporting ring 9.

6. ➔ Use the extractor to pull the pole wheel 7 and distance ring 8 from the measuring screw large 17.

7. ➔ Use the extractor to pull out the screw set from the bearing cover 3.

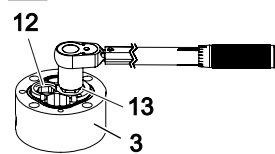

8. ➔ Screw the threaded rings 12 and 13 out of the bearing cover 3.

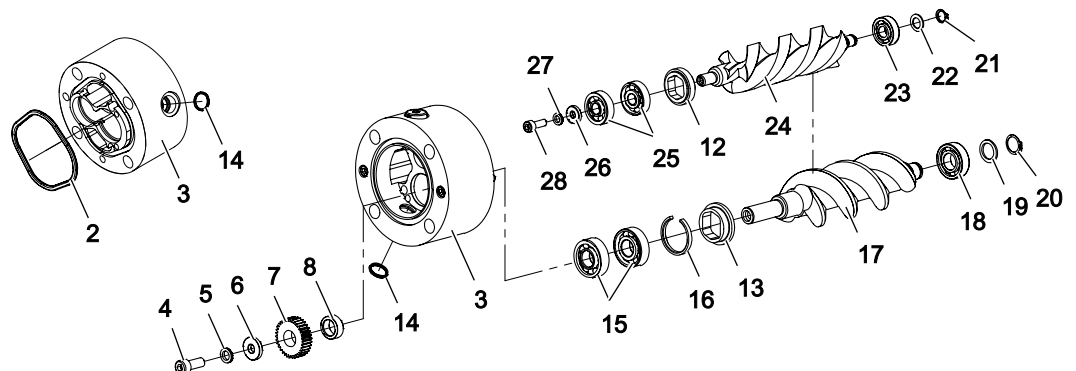

9. ➤ Use an extractor to take out the distance ring **16** and pull the angular-contact ball bearings **15** and **25** out of the bearing cover **3**.
10. ➤ Remove the circlip **20** and support ring **19** from the measuring screw large **17** and pull off the ball bearing **18** using an extractor.
11. ➤ Remove the circlip **21** and support ring **22** from the measuring screw small **24** and pull off the ball bearing **23** using an extractor.
12. ➤ Remove the O-ring **14** from the pick up hole in the bearing cover **3**.

12.2.6 Installing seals and ball bearings OMG-052/OMG-068

Personnel qualification:	<input type="checkbox"/> Fitter
Personal protective equipment:	<input type="checkbox"/> Work clothing <input type="checkbox"/> Protective gloves <input type="checkbox"/> Safety boots
Aids:	<input type="checkbox"/> Torque wrench

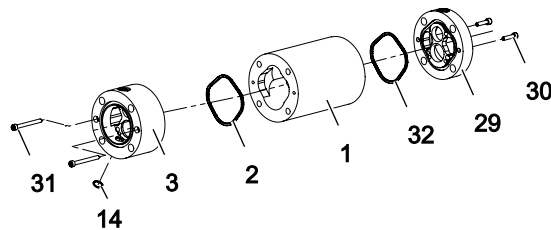

1. ➤ Insert the O-ring **2** and **32** into the bearing cover **3** and **29** and insert the O-ring **14** into the pick up hole in the bearing cover.

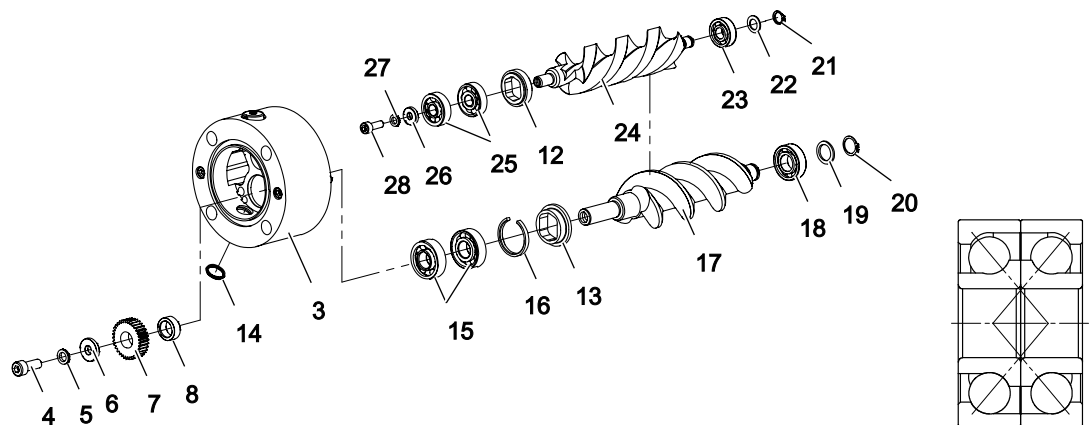

2. ➤ Press in the angular-contact ball bearings **15** and **25** in X-layout via the outer ring of the ball bearing in the bearing cover **3**.
3. ➤ Place the distance ring **16** onto the angular-contact ball bearing **15**.
4. ➤ Press the ball bearing **18** over the inner ring of the ball bearing onto the measuring screw large **17**.
5. ➤ Press the ball bearing **23** over the inner ring of the ball bearing onto the measuring screw small **24**.

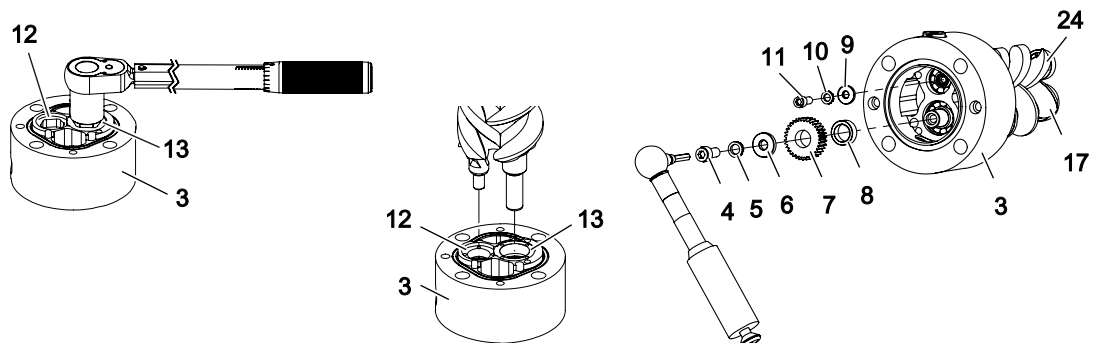

6. ➤ First screw in the threaded ring small **12**, then the threaded ring large **13** into the bearing cover **3**. Tightening torques for threaded rings ➤ Appendix, Page 54.

12 Servicing

12.2 Replacing seals and ball bearings

7. ➤ Press the measuring screws into the ball bearings in the bearing cover **3**. Support the respective inner ring of the ball bearing.
8. ➤ Slide the distance ring **8** on the measuring screw large **17** and press on the pole wheel **7**.
9. ➤ Pull the wedge lock washers **10** and supporting ring **9** onto the socket screw **11**. Observe the layout of the wedge lock washer (wedge on wedge).
10. ➤ Apply Loctite 242 to the socket screw **11** and install on the measuring screw small **24**.
11. ➤ Pull the wedge lock washers **5** and supporting ring **6** onto the socket screw **4**. Observe the layout of the wedge lock washer (wedge on wedge).
12. ➤ Apply Loctite 242 to the socket screw **4** and install on the measuring screw large **17**.

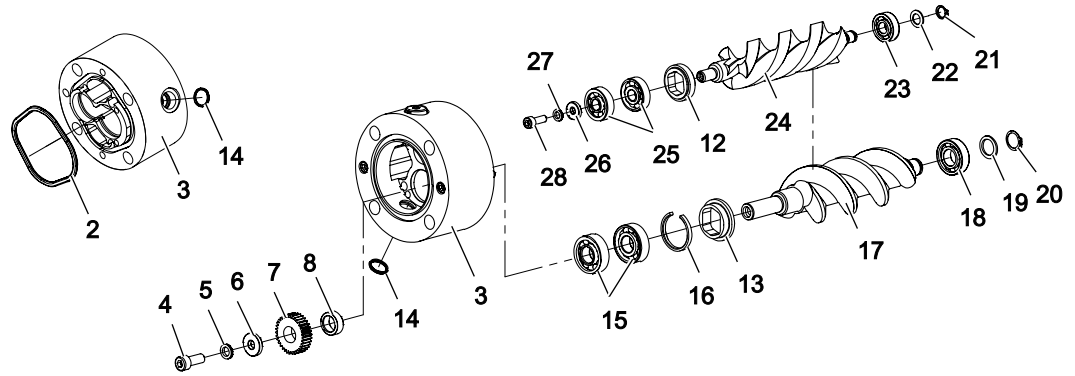

13. ➤ Install the support rings **19** and **22** as well as the circlips **20** and **21** on the floating bearing end.

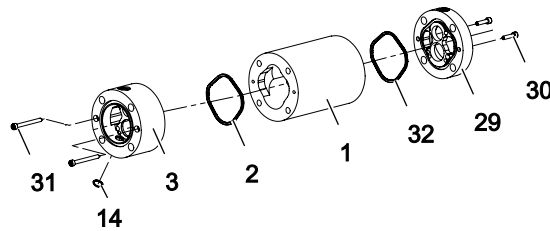

14. ➤ Insert the O-ring **32** into the bearing cover **29**.
15. ➤ Place the bearing cover **29** onto the measuring housing **1** and tighten the socket screws **30** with torque.
16. ➤ Carefully insert the bearing cover **3** with premounted measuring unit into measuring housing **1** and tighten the socket screws **31** with torque.

12.2.7 Removing seals and ball bearings OMG-100/OMG-140

Personnel qualification:	<input type="checkbox"/> Fitter
Personal protective equipment:	<input type="checkbox"/> Work clothing <input type="checkbox"/> Protective gloves <input type="checkbox"/> Safety boots
Aids:	<input type="checkbox"/> Plastic hammer <input type="checkbox"/> Extractor

Requirement:

- ✓ Flowmeter removed from system
- ✓ Completion consisting of socket screws, flanges and seals removed
- ✓ Pick up inserts removed

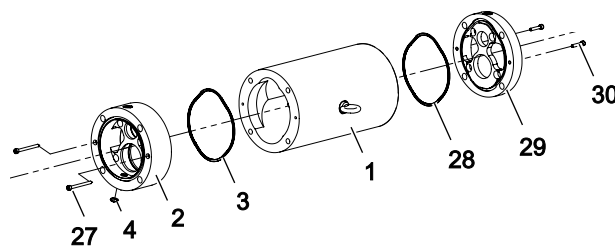

1. ➤ Remove the socket screws **27** and **30**, take off the bearing cover **29** and remove the O-ring **28**.

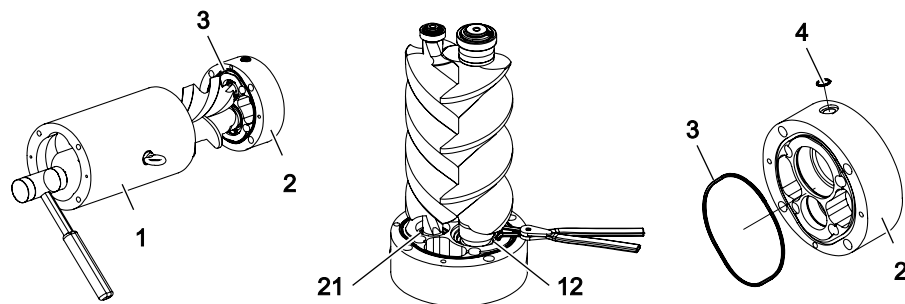

2. ➤ Drive the screw set together with the bearing cover 2 out of the measuring housing 1 using light blows of a plastic hammer and pull out.
3. ➤ Loosen the circlips 12 and 21 out of grooves in the bearing cover.

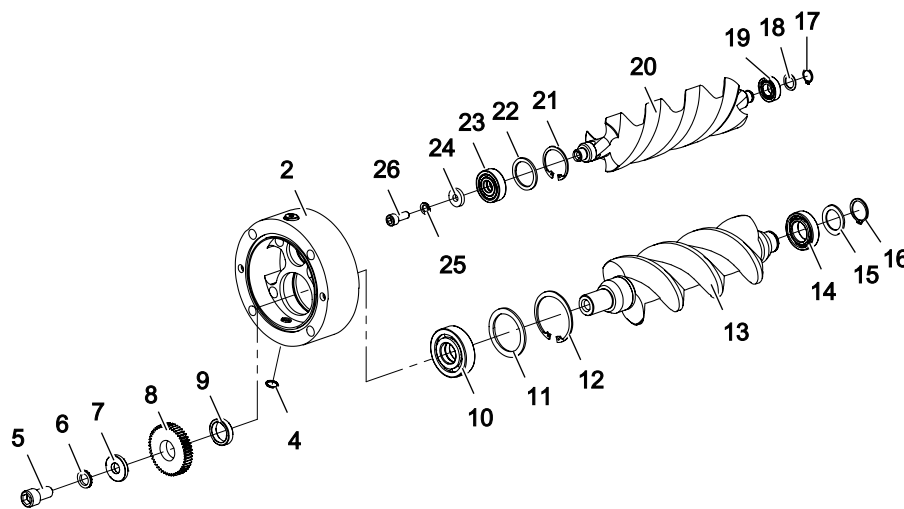

4. ➤ Unscrew the socket screw 5, take off the wedge lock washers 6 and supporting ring 7.
5. ➤ Screw the socket screw 5 completely back in, in order to pull the pole wheel 8 and bearing cover 2 from the screw set by using an extractor. Remove the distance ring or sleeve 9. Remove the socket screw 5 again.
6. ➤ Remove the measuring screws from the bearing cover 2.
7. ➤ Remove the O-ring 4 via the hole in the middle of the bearing cover 2.
8. ➤ Unscrew the socket screw 26, remove the wedge lock washers 25 and supporting ring 24.
9. ➤ Remove the circlip 16 and support ring 15 from the measuring screw large 13.
10. ➤ Remove the circlip 17 and support ring 18 from the measuring screw small 20.
11. ➤ Use the extractor to pull the ball bearings 14 and 10 from the measuring screw large 13.
12. ➤ Use the extractor to pull the ball bearings 19 and 23 from the measuring screw small 20.
13. ➤ Remove the support rings 11 and 22 from the measuring screws.

12.2.8 Installing seals and ball bearings OMG-100/OMG-140

Personnel qualification:	<input type="checkbox"/> Fitter
Personal protective equipment:	<input type="checkbox"/> Work clothing <input type="checkbox"/> Protective gloves <input type="checkbox"/> Safety boots
Aids:	<input type="checkbox"/> Torque wrench

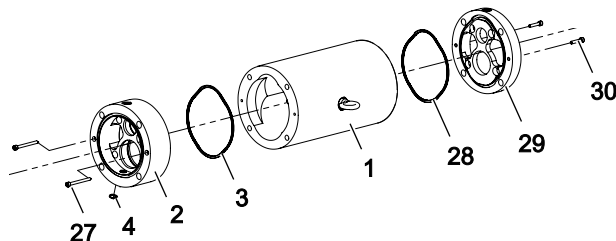

1. ➤ Insert the O-ring 3 into the bearing cover 2 and insert the O-ring 28 into the bearing cover 29.

2. ➤ Insert the O-ring **4** via the hole in the middle of the bearing cover **2** in the pick up hole.

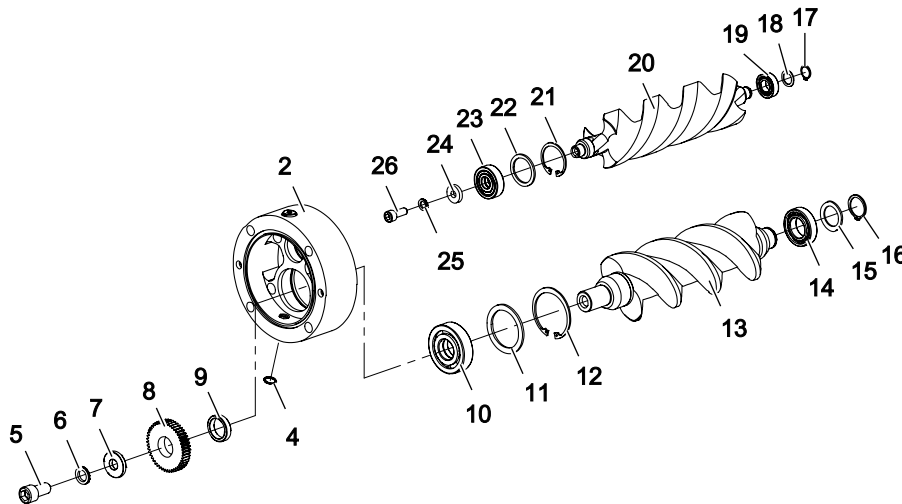

3. ➤ Slide the circlip **12** and support ring **11** onto the measuring screw large **13**.
 4. ➤ Slide the circlip **21** and support ring **22** onto the measuring screw small **20**.
 5. ➤ Press on the ball bearings **10**, and **14** over the inner ring of the ball bearing onto the measuring screw large **13**.
 6. ➤ Press on the ball bearings **23** and **19** over the inner ring of the ball bearing on the measuring screw small **20**.
 7. ➤ Pull the wedge lock washers **25** and supporting ring **24** onto the socket screw **26**. Observe the layout of the wedge lock washer (wedge on wedge).
 8. ➤ Apply Loctite 242 to the socket screw **26** and install on the measuring screw small **20**. Tighten with torque.

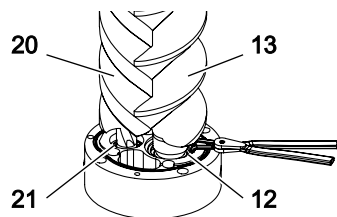

9. ➤ Insert the measuring screws into the bearing cover **2** and install the circlips **12** and **21**.
 10. ➤ Slide the distance ring or sleeve **9** on the measuring screw large **13** and press on the pole wheel **8**.
 11. ➤ Pull the wedge lock washers **6** and supporting ring **7** onto the socket screw **5**. Ensure the correct positioning of the wedge lock washers (wedge on wedge).
 12. ➤ Apply Loctite 242 to the socket screw **5** and install on the measuring screw large **13**. Tighten with torque.
 13. ➤ Install the support rings **15** and **18** as well as the circlips **16** and **17** on the floating bearing end.
 14. ➤ Carefully insert the bearing cover **2** with premounted measuring unit into the measuring housing **1**, tighten the socket screws **27** with torque.
 15. ➤ Place the bearing cover **29** onto the measuring housing **1** and tighten the socket screws **30** with torque.

13 Disposal

13.1 Dangers during disposal



The following safety instructions must be observed strictly:

- Neutralize residues.

13.2 Dismantling and disposing of the flowmeter

Personnel qualification:	<input type="checkbox"/> Fitter
Personal protective equipment:	<input type="checkbox"/> Work clothing <input type="checkbox"/> Face protection <input type="checkbox"/> Protective gloves <input type="checkbox"/> Safety boots
Aids:	<input type="checkbox"/> Solvents or industrial cleaners suitable for the pumped liquid <input type="checkbox"/> Collection tank



DANGER

Risk of death resulting from electric shock when removing the optional electrical heating system.

- ▶ Ensure that the electrical power supply is de-energized and is secured against being switched back on.
- ▶ The flowmeter may only be disconnected from the power supply by an authorized electrician.



WARNING

Danger of poisoning and environmental damage through residues.

- ▶ Wear personal protective clothing during all the work. Ensure face protection.
- ▶ Before disposal collect any pumped liquid still present safely and dispose of it in an environmentally compatible manner in accordance with the applicable local regulations.
- ▶ Before disposing neutralize the residues.

Requirement:

- ✓ Flowmeter cooled down to the ambient temperature and disconnected from the pipe system
 - ✓ Flowmeter drained completely
 - ✓ Flowmeter placed at a location suitable for dismantling
1. ▶ Dismantle the flowmeter and disassemble it into its individual parts.
 2. ▶ Clean residues of the pumped liquid from the individual parts.
 3. ▶ Separate sealing elements made of elastomer from the flowmeter and dispose of them separately.
 4. ▶ Recycle iron parts.

14 Troubleshooting

14.1 Possible faults

14 Troubleshooting

14.1 Possible faults

Faults can have different causes. The following tables list the symptoms of a fault, the possible causes and measures for troubleshooting.

In the case of faults please contact the manufacturer. Under services@kral.at.

Identification	Fault
1	Flowmeter leaks
2	No flow rate
3	Flowmeter does not generate a pulse
4	Pressure loss too high
5	Measured values not realistic

14.2 Troubleshooting

Fault identification	Cause	Remedy
1	– – – – Seal preload too low	—▶ Preload the screws.
1	– – – – Seal damaged	—▶ Replace the seal. —▶ Check the chemical resistance of the seal.
– 2 3 – 5	Foreign particles in the liquid and/or flowmeter	—▶ Dismantle the flowmeter and clean it. —▶ Use the commissioning filter.
– – 3 – 5	Pick up not connected correctly	—▶ Check the power supply for the pick up. In the process observe the operating instructions of the pick up.
– – 3 – 5	Pick up defective	—▶ Check the function of the pick up. In the process observe the operating instructions of the pick up.
1 – 3 – –	Dry sleeve destroyed	—▶ Replace the dry sleeve. Contact the manufacturer in the process.
– 2 3 – –	Inlet pressure too low	—▶ Increase the inlet pressure.
– – – 4 –	Viscosity of the liquid too high	—▶ Increase the temperature. When doing so observe the temperature range.
– – 3 – –	Flow rate too low	—▶ Increase the flow rate. -or- Use a flowmeter with a suitable size. -or- Use linearization. In the process observe the operating instructions of the electronic equipment.
– – – 4 –	Flow rate too high	—▶ Reduce the flow. -or- Use a flowmeter with a suitable size.
– – – – 5	Airlocks	—▶ Deaerate the system and check for leaks.

Fault identification					Cause	Remedy
-	-	-	-	5	Outgassing	<ul style="list-style-type: none"> —▶ Increase the system pressure. —▶ Reduce the temperature.
-	-	-	-	5	Pulsations too high	<ul style="list-style-type: none"> —▶ Use another feed pump. —▶ Carry out changes to the system.
-	-	-	-	5	Back pressure too low	<ul style="list-style-type: none"> —▶ Increase the back pressure.
-	-	-	-	5	Flow rate fluctuations too high	<ul style="list-style-type: none"> —▶ Ensure a continuous flow rate by taking suitable measures (use of a different pump, valve, damper, etc.). -or- Smoothen the indication. In the process observe the operating instructions of the electronic equipment.
-	-	3	-	5	Filling amount too low	<ul style="list-style-type: none"> —▶ Use a flowmeter with a suitable size. —▶ Use a flowmeter from a suitable series.
-	-	-	-	5	Strongly deviating operating data	<ul style="list-style-type: none"> —▶ Use a flowmeter from a suitable series. —▶ Adapt the operating data to the flowmeter.
-	2	3	4	5	Wear at the measuring unit and bearings	<ul style="list-style-type: none"> —▶ Replace the measuring unit. —▶ Replace the bearings. —▶ Filter out the abrasive materials.
-	-	-	4	5	Sluggishness through deposits	<ul style="list-style-type: none"> —▶ Disassemble the flowmeter and clean it carefully.
-	2	3	-	-	Flow impaired at the system end	<ul style="list-style-type: none"> —▶ Check whether the fluid flows in the system (pump in operation, slide valve opened, etc.). —▶ Check whether shut-off devices before and after the flowmeter are opened.
-	2	3	-	-	Flowmeter switched to bypass	<ul style="list-style-type: none"> —▶ Switch the flowmeter to through-flow.

Tab. 11: Fault table

15 Spare parts

15.1 Overview OMG-013

15 Spare parts

15.1 Overview OMG-013

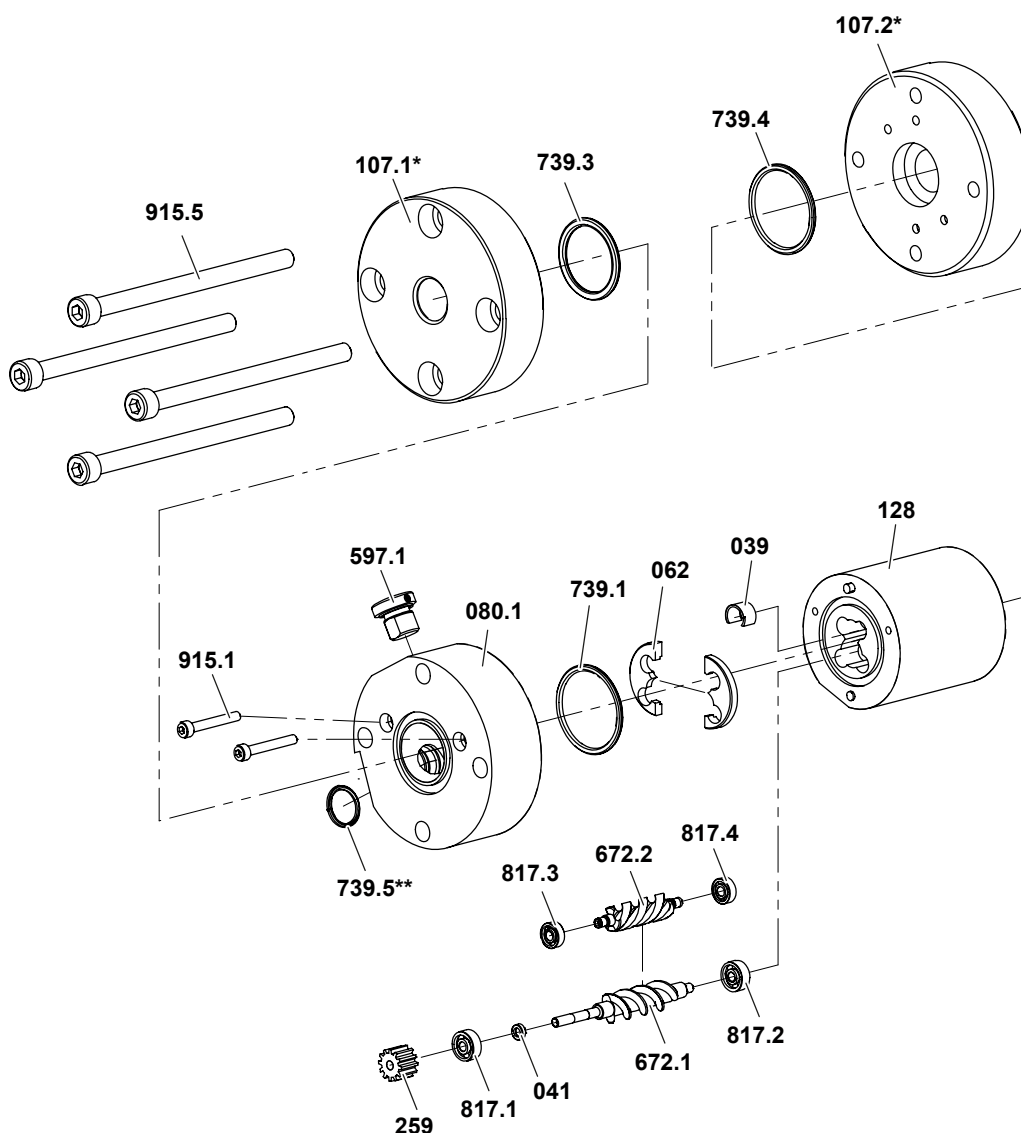

Item No.	Part	Item No.	Part
039	Distance sleeve	739.5**	O-ring
062	Spacer	817.1	Deep-groove ball bearing
080.1	Bearing cover	817.2	Deep-groove ball bearing
107.1*	Pipe thread connection	817.3	Deep-groove ball bearing
107.2*	Pipe thread connection	817.4	Deep-groove ball bearing
128	Measuring housing	869.4	Circlip
259	Pole wheel	870.1	Circlip
597.1	Screw plug	870.2	Circlip
672.1	Measuring screw large	904.1	Wedge lock washer
672.2	Measuring screw small	904.2	Wedge lock washer
739.1	O-ring	915.1	Socket screw
739.3	O-ring	915.5	Socket screw
739.4	O-ring		
*	Parts alternatively for pipe thread connection or flange connection		
**	Exist twice at two pick up holes		

Tab. 12: List of parts

15.2 Overview OMG-020/OMG-032

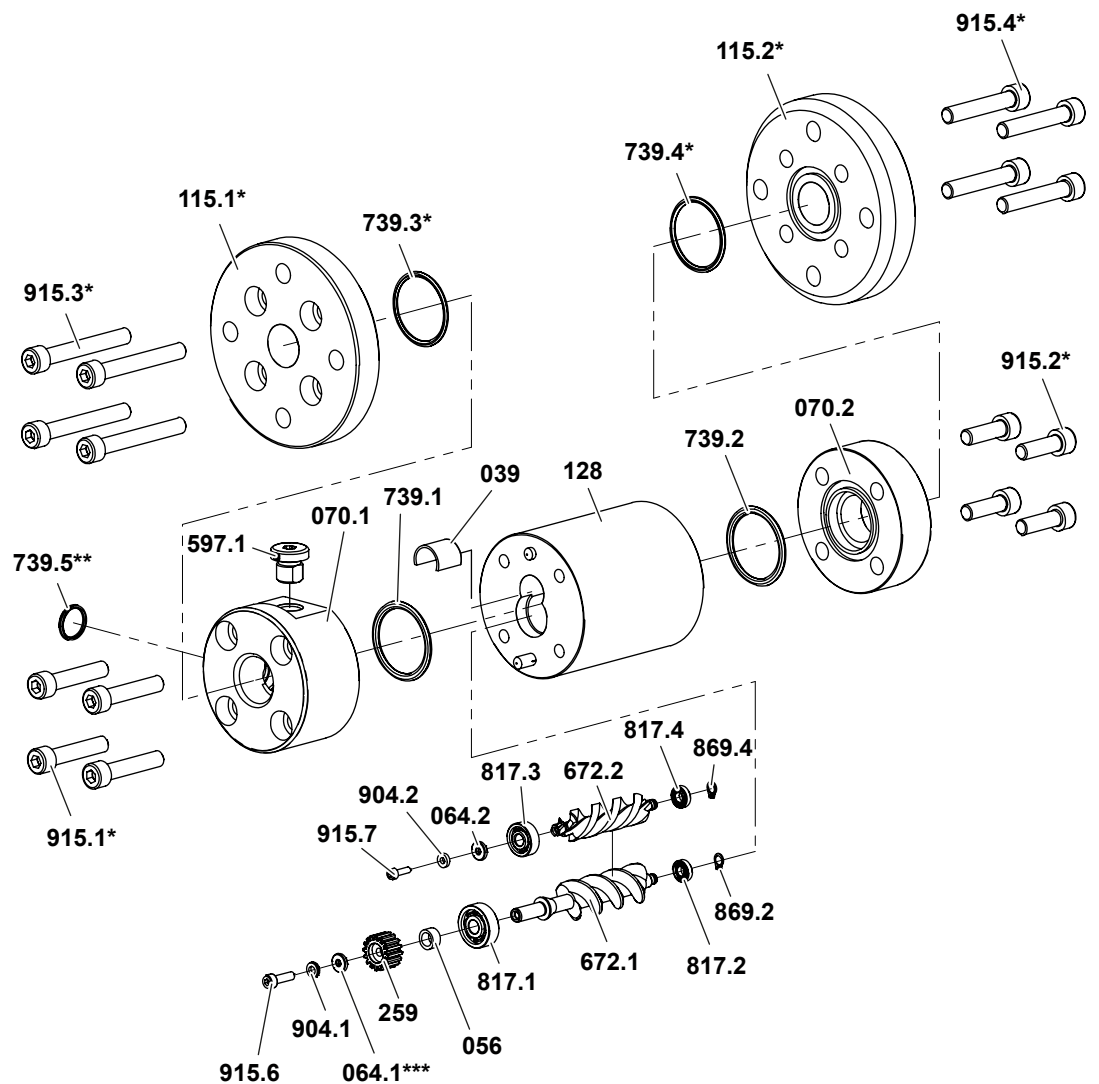

Item No.	Part	Item No.	Part
039	Distance sleeve	739.4*	O-ring
056	Distance ring	739.5**	O-ring
064.1****	Supporting ring	817.1	Deep-groove ball bearing
064.2	Supporting ring	817.2	Deep-groove ball bearing
070.1	End cover	817.3	Deep-groove ball bearing
070.2	End cover	817.4	Deep-groove ball bearing
115.1*	Flange	869.2	Circlip
115.2*	Flange	869.4	Circlip
128	Measuring housing	904.1	Wedge lock washer
259	Pole wheel	904.2	Wedge lock washer
597.1	Screw plug	915.1*	Socket screw
672.1	Measuring screw large	915.2*	Socket screw
672.2	Measuring screw small	915.3*	Socket screw
739.1	O-ring	915.4*	Socket screw
739.2	O-ring	915.6	Socket screw
739.3*	O-ring	915.7	Socket screw
*	Parts alternatively for pipe thread connection or flange connection		

15 Spare parts

15.3 Overview OMG-052/OMG-068

Item No.	Part	Item No.	Part
**	Exist twice at two pick up holes		
****	Only for OMG-032		

Tab. 13: List of parts

15.3 Overview OMG-052/OMG-068

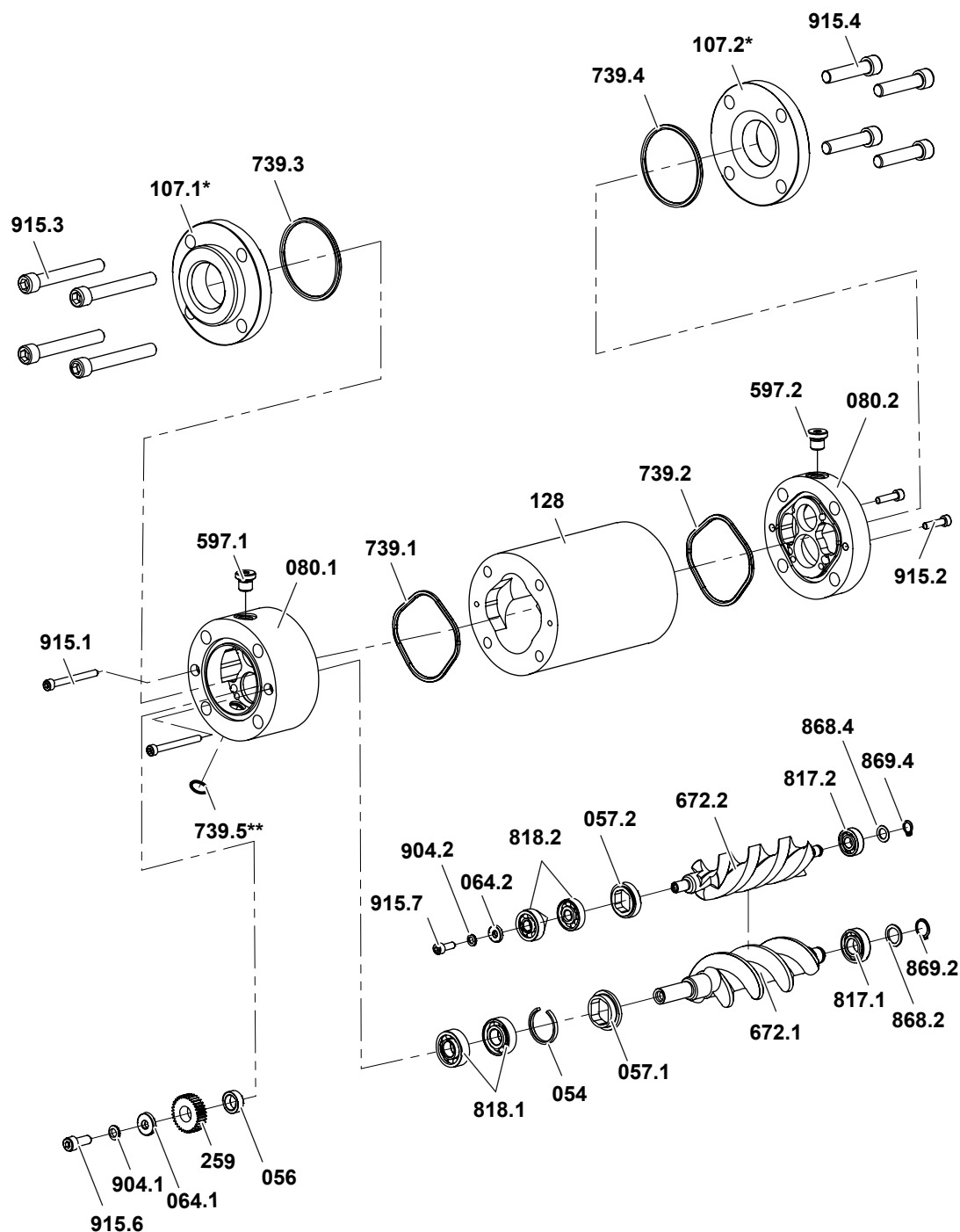

Item No.	Part	Item No.	Part
054	Distance ring	739.4	O-ring
056	Distance ring	739.5**	O-ring
057.1	Threaded ring	817.1	Deep-groove ball bearing
057.2	Threaded ring	817.2	Deep-groove ball bearing
064.1	Supporting ring	818.1	Angular-contact ball bearing

Item No.	Part	Item No.	Part
064.2	Supporting ring	818.2	Angular-contact ball bearing
080.1	Bearing cover	868.2	Support ring
080.2	Bearing cover	868.4	Support ring
107.1*	Pipe thread connection	869.2	Circlip
107.2	Pipe thread connection	869.4	Circlip
128	Measuring housing	904.1	Wedge lock washer
259	Pole wheel	904.2	Wedge lock washer
597.1	Screw plug	915.1	Socket screw
597.2	Screw plug	915.2	Socket screw
672.1	Measuring screw large	915.3	Socket screw
672.2	Measuring screw small	915.4	Socket screw
739.1	O-ring	915.6	Socket screw
739.2	O-ring	915.7	Socket screw
739.3	O-ring		
*	Parts alternatively for pipe thread connection or flange connection		
**	Exist twice at two pick up holes		

Tab. 14: List of parts

15.4 Overview OMG-100/OMG-140

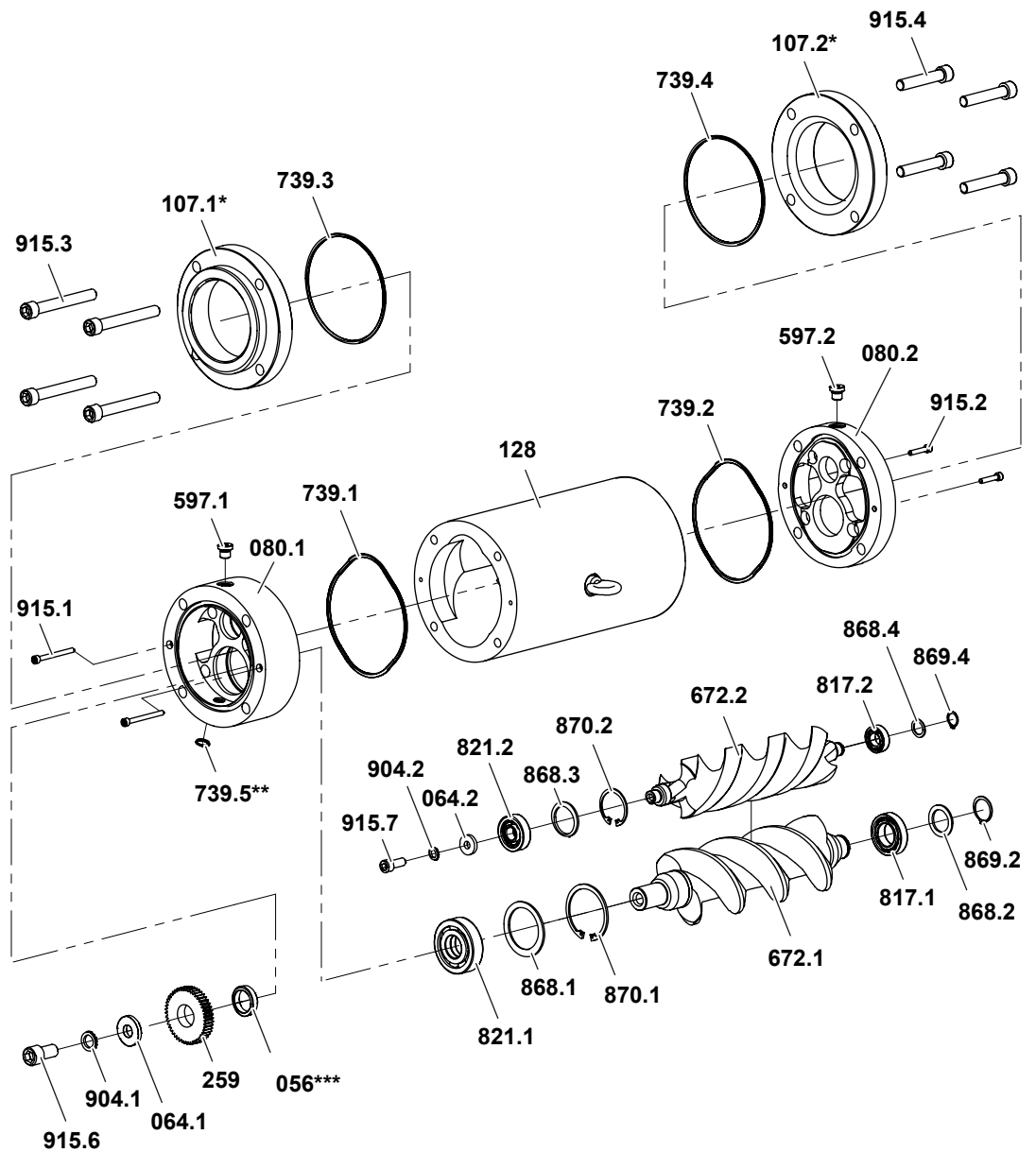

Item No.	Part	Item No.	Part
056***	Distance ring	821.1	Four-point contact bearings
064.1	Supporting ring	821.2	Four-point contact bearings
064.2	Supporting ring	868.1	Support ring
080.1	Bearing cover	868.2	Support ring
080.2	Bearing cover	868.3	Support ring
107.1*	Pipe thread connection	868.4	Support ring
107.2*	Pipe thread connection	869.2	Circlip
128	Measuring housing	869.4	Circlip
259	Pole wheel	870.1	Circlip
597.1	Screw plug	870.2	Circlip
597.2	Screw plug	904.1	Wedge lock washer
672.1	Measuring screw large	904.2	Wedge lock washer
672.2	Measuring screw small	915.1	Socket screw
739.1	O-ring	915.2	Socket screw

Item No.	Part	Item No.	Part
739.2	O-ring	915.3	Socket screw
739.3	O-ring	915.4	Socket screw
739.4	O-ring	915.6	Socket screw
739.5**	O-ring	915.7	Socket screw
817.1	Deep-groove ball bearing		
817.2	Deep-groove ball bearing		
*	Parts alternatively for pipe thread connection or flange connection		
**	Exist twice at two pick up holes		
***	For OMG-140: replaced by sleeve, spare part 041		

Tab. 15: List of parts

16 Accessories

16.1 Heating

16.1.1 Possible types of heating

The flowmeter can optionally be equipped with a heating system. The manufacturer recommends a heating system at high-viscosity liquids that do not flow sufficiently if not heated since this can lead to damage to bearings and destruction of the device.

Type of heating	Note
Electrical heating system	The electrical heating system consists of a tubular pipe cartridge with a heating sleeve.
Fluid heating system	The fluid heating system consists of a heating jacket and pipe thread connections.
Trace heating provided by the customer	Before installing trace heating provided by the customer, contact the manufacturer.

16.1.2 Technical data of the electrical heating system

	Unit	013	020/032	052	068/100	140
Heating output	[W]	180	180	800	2000	On request
Voltage	[V AC]	230				
Frequency	[Hz]	50				
Wire cross-section	[mm ²]	3 x 0.75				
Cable length for tubular pipe cartridge	[m]	1				

Tab. 16: Electrical heating system

16.1.3 Technical data of the fluid heating system

	Unit	020/032	052	068/100	140
Max. pressure	[bar]	16			
Max. temperature of the liquid	[°C]	200			

Tab. 17: Fluid heating system

16.1.4 Installing the heating system

Installing the electrical heating system

Personnel qualification:	<input type="checkbox"/> Fitter <input type="checkbox"/> Electrician
Personal protective equipment:	<input type="checkbox"/> Work clothing <input type="checkbox"/> Protective gloves <input type="checkbox"/> Safety boots



⚠ DANGER

Risk of death resulting from electric shock.

- ▶ Ensure that the electrical power supply is de-energized and is secured against being switched back on.
- ▶ Observe the operating instructions of the electrical components.



Fig. 9: Tubular pipe cartridge with heating sleeve

—▶ Envelop the flowmeter with the heating sleeve with tubular pipe cartridge lying on the inside.

Notice If a tubular pipe cartridge is used, the manufacturer recommends insulating the flowmeter and heating system in order to avoid radiation losses.

Installing the fluid heating system

Personnel qualification:	<input type="checkbox"/> Fitter
Personal protective equipment:	<input type="checkbox"/> Work clothing <input type="checkbox"/> Protective gloves <input type="checkbox"/> Safety boots

ATTENTION

Damage to equipment through the use of water or steam as a heating liquid.

- ▶ Use a suitable heating liquid, such as heat transfer oil.

—▶ Envelop the flowmeter with heating jack.

Installing the trace heating

Notice Before installing trace heating provided by the customer, contact the manufacturer.

Personnel qualification:	<input type="checkbox"/> Fitter
Personal protective equipment:	<input type="checkbox"/> Work clothing <input type="checkbox"/> Protective gloves <input type="checkbox"/> Safety boots

ATTENTION

Defective components through the maximum temperature being exceeded.

- ▶ Do not heat the pick up, temperature sensor, junction box and associated cables above the temperature specified in the associated operating instructions.

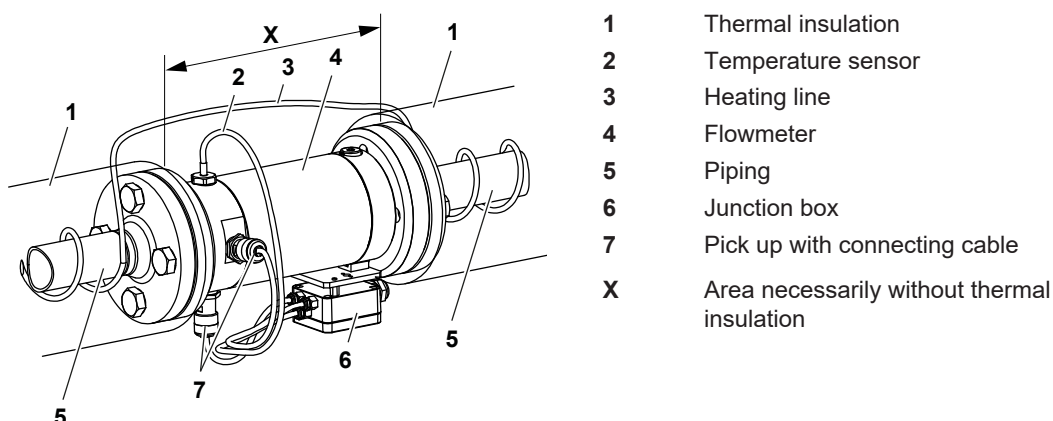

Fig. 10: Flowmeter with trace heating

► Wind the heating line 3 around the piping 5. Ensure that the pick up 7, temperature sensor 2, junction box 6 and associated cables are not thermally insulated. The area X must remain free of thermal insulation.

16.2 Junction box

16.2.1 Function description

For the flowmeters the manufacturer offers a junction box. This simplifies the electrical connection of the various sensors.

16.2.2 Technical data

	Unit	UZA 09	UZA 10	UZA 11
Suitable for		Pick up BEG 43, BEG 44 Temperature sensor EET 32, EET 33, EET 34		
Electrical specification				
<input type="checkbox"/> Number of sensor inputs		1	2	3
<input type="checkbox"/> Number of outputs		1	1	1
Mechanical specification				
<input type="checkbox"/> Max. liquid temperature	[°C]	150		
<input type="checkbox"/> Housing material		Aluminium		
<input type="checkbox"/> Connection thread		M6		
<input type="checkbox"/> Fastening		Direct installation on the flowmeter (except OMG-013)		

Tab. 18: Junction box

16.2.3 Installing the junction box

Personnel qualification:	<input type="checkbox"/> Fitter <input type="checkbox"/> Electrician
Personal protective equipment:	<input type="checkbox"/> Work clothing <input type="checkbox"/> Protective gloves <input type="checkbox"/> Safety boots



⚠ DANGER

Risk of death resulting from electric shock.

- Ensure that the electrical power supply is de-energized and is secured against being switched back on.
- Observe the operating instructions of the electrical components.

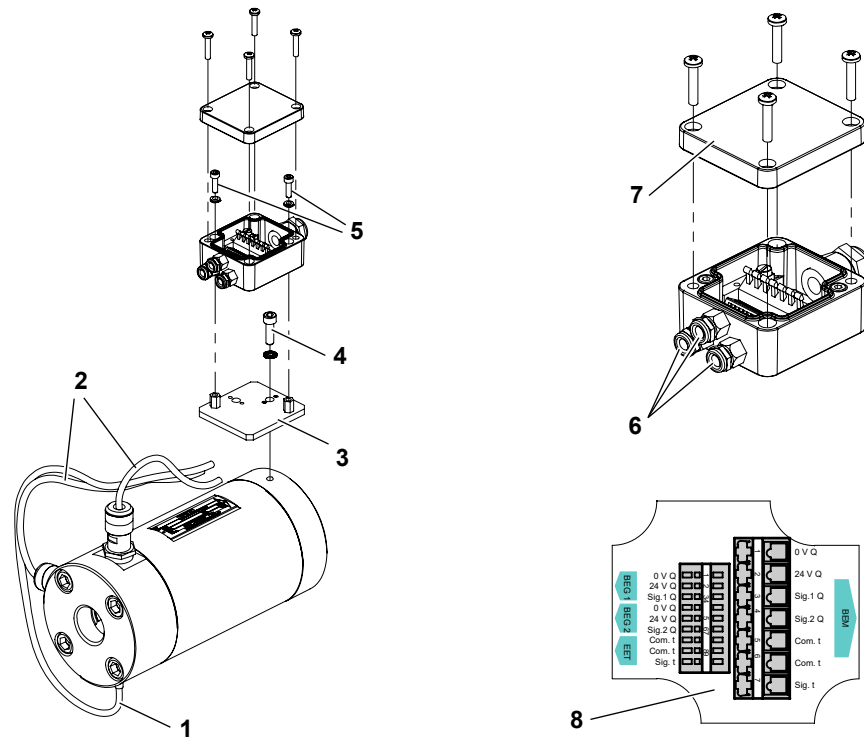

Fig. 11: Installing and connecting the junction box

- | | | | |
|---|--------------------------|---|---------------------------|
| 1 | Temperature sensor cable | 5 | Socket screw and washer |
| 2 | Pick up cable | 6 | Cable gland sensor inputs |
| 3 | Junction box base plate | 7 | Junction box cover |
| 4 | Socket screw and washer | 8 | Connection diagram |

1. ➤ Pinch off the pick up cable 2 and temperature sensor cable 1. Ensure sufficient cable length.
2. ➤ Fasten the base plate 3 of the junction box to the flowmeter using the socket screw and washer 4.
3. ➤ Fasten the lower part of the junction box to the base plate using socket screws 5.
4. ➤ Carry out the cabling through the cable gland 6. Observe the connection diagram 8.
5. ➤ Screw tight the cover 7 of the junction box.

16.3 Extension cable

16.3.1 Function description

Normally the cable length does not influence the functionality of the sensors. Nevertheless the manufacturer recommends that connecting cables of the junction box be extended to a maximum length of 100 m. Extension cables as well cable connectors and cable box are available as accessories from the manufacturer.

16.3.2 Technical data

	Unit	
Max. length	[m]	100
Cable diameter	[mm]	6.0 – 10.5
Wire cross-section min. – max.	[mm ²]	0.25 – 2.50 (single wire)
	[mm ²]	0.25 – 1.50 (multiple wires)

Tab. 19: Extension cable

16.3.3 Connecting the extension cable

Personnel qualification:	<input type="checkbox"/> Electrician
Personal protective equipment:	<input type="checkbox"/> Work clothing



DANGER

Risk of death resulting from electric shock.

- ▶ Ensure that the electrical power supply is de-energized and is secured against being switched back on.
- ▶ Observe the operating instructions of the electrical components.

ATTENTION

Damage to equipment through incorrect connecting of the extension cable.

- ▶ Use only a shielded extension cable.
 - ▶ Lay extension cables separately from the supply lines.
1. ▶ Solder the cable connector onto the sensor cable.
 2. ▶ Solder the cable box to the extension cable.
 3. ▶ Connect the sensor cable and extension cable.
 4. ▶ Connect the extension cable in accordance with the connection diagram.

17 Appendix

17.1 Tightening torques for screws with metric screw threads with and without wedge lock washers

Tightening torque [Nm]							
Screws with head contact surface					Countersunk screws		
Thread	5.6	8.8	10.9	8.8+ Alu*	Stainless steel screws A2 and A4		8.8
					Property class 70	Property class 80	
M 3	0.6	1.5	–	1.2	–	–	1
M 4	1.4	3.0	4.1	2.3	–	–	2
M 5	2.7	6.0	8.0	4.8	3.5	4.7	5
M 6	4.7	10.3	14.0	7.6	6.0	8.0	9
M 8	11.3	25.0	34.0	18.4	16.0	22.0	14
M 10	23.0	47.0	68.0	36.8	32.0	43.0	36
M 12	39.0	84.0	117	64.0	56.0	75.0	60
M 14	62.0	133	186	101	–	–	90
M 16	96.0	204	285	155	135	180	100
M 18	133	284	390	224	–	–	–
M 20	187	399	558	313	280	370	135
M 24	322	687	960	540	455	605	360

Tab. 20: Tightening torques metric screw thread

*When screwing into aluminium, the tightening torque reduces by 20 % when the screw-in depth is less than double the thread diameter.

17.2 Tightening torques for screw plugs with thread measured in inches and elastomer seal

Tightening torque [Nm]	
Thread	Galvanized + stainless steel
G 1/8"	13.0
G 1/4"	30.0
G 3/8"	60.0
G 1/2"	80.0
G 3/4"	120
G 1"	200
G 1 1/4"	400
G 1 1/2"	450

Tab. 21: Tightening torques, thread measured in inches

17.3 Tightening torques and widths for threaded rings

Size	Threaded ring/ measuring screw	Item No.	Width [mm]	Tightening torque [Nm]
052	Large	057.1	22	60
	Small	057.2	19	52
068	Large	057.1	32	160
	Small	057.2	19	55

Tab. 22: Tightening torques and widths for threaded rings

17.4 Contents of the Declaration of Conformity

The products described in these instructions are machinery in the sense of the Directive 2006/42/EC. The original of the EC Declaration of Conformity is enclosed with the machinery at delivery.

The machinery fulfils all the relevant provisions of the following directives:

Number	Name	Remark
2006/42/EC	Machinery Directive	–
2014/68/EU	Pressure Equipment Directive	–
2014/30/EU	Directive on Electromagnetic Compatibility	Only for machinery with electrical components
2014/35/EU	Low Voltage Directive	Only for machinery with electrical components
2014/34/EU	Directive on Use in Potentially Explosive Areas (ATEX)	Only for machinery in ATEX version

Tab. 23: Directives observed



KRAL

